



SA36 and SC36 FIREPLACES

INSTALLATION, OPERATION AND MAINTENANCE MANUAL

FOR RESIDENTIAL INSTALLATION

THE ABOVE LISTED FIREPLACES ARE U.L. LISTED FOR USE WITH EITHER THE MARTIN "S" SERIES OR "E" SERIES CHIMNEY SYSTEM COMPONENTS. DO NOT MIX CHIMNEY SYSTEM COMPONENTS FROM ONE SERIES TO ANOTHER.

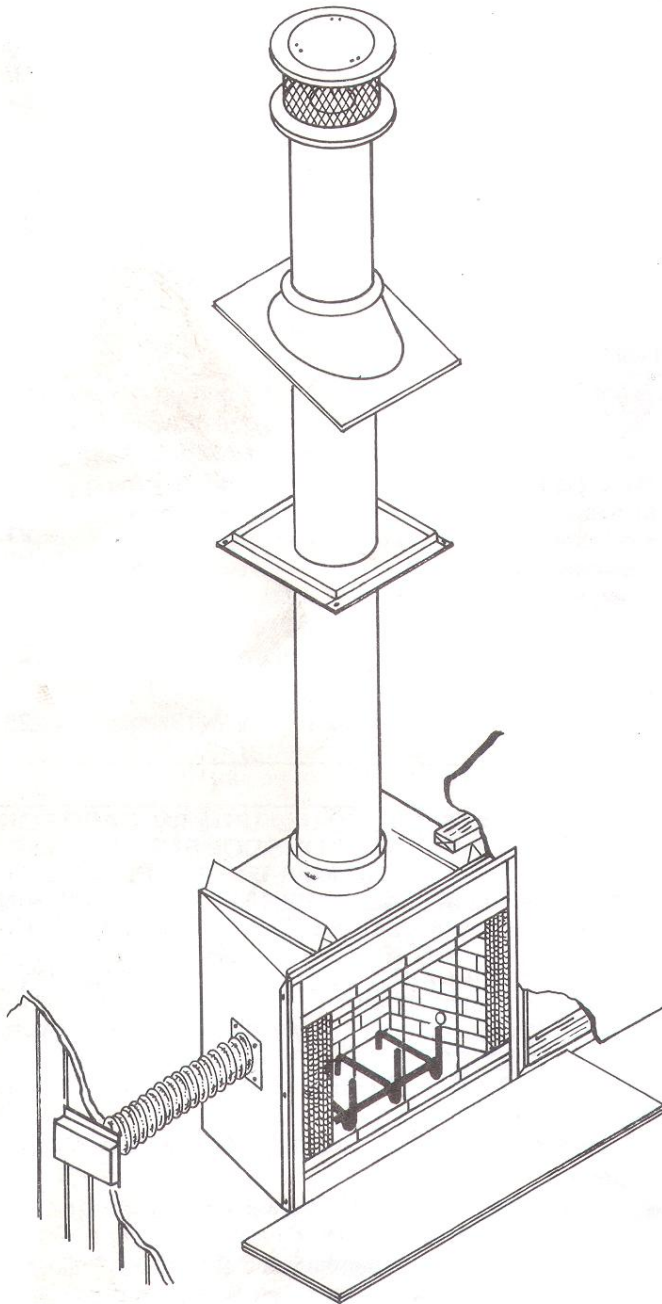

36 INCH BUILT-IN WOOD BURNING
FIREPLACE WITH OPTIONAL OUT-
SIDE AIR FOR COMBUSTION, GLASS
DOORS, AND FAN ASSEMBLY

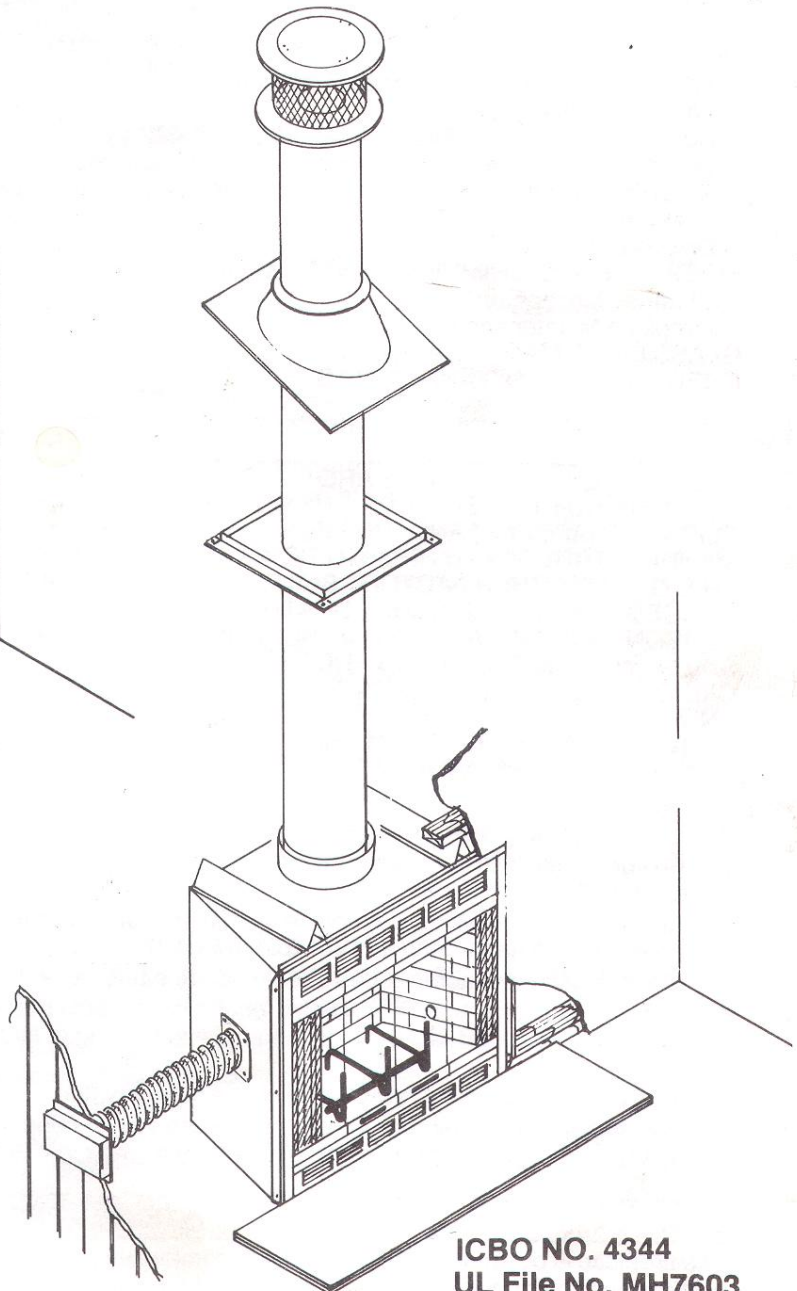

ICBO NO. 4344
UL File No. MH7603

CONTENTS

IMPORTANT NOTICES	2
INTENDED PRODUCT USAGE	2
IMPROPER INSTALLATION	3
HOW THIS FIREPLACE OPERATES	3
BUILDING CODES AND SAFETY REQUIREMENTS	3
SELECTING A LOCATION	5
FLOOR PROTECTION	8
Safety Strip Installation	8
Hearth Extension Equivalents	8
INSPECTION OF FIREPLACE COMPONENTS	10
FIREPLACE INSTALLATION	10
CHIMNEY INSTALLATION	12
CHIMNEY OFFSET INSTALLATION	12
Elbow Installation	14
Offset Installation Sequence	14
CHIMNEY CAP INSTALLATION	15
MODEL SCL OR TCSQL8 CHIMNEY CAP FOR CHASE INSTALLATION	16
OUTSIDE COMBUSTION AIR PRECAUTIONS AND RECOMMENDATIONS	17
COMBUSTION AIR ASSEMBLY INSTALLATION PROCEDURE	18
INSTALLATION OF GAS APPLIANCE IN THE FIREPLACE	19
APPLYING DECORATIVE TRIM TO THE FIREPLACE	20
GLASS DOOR INSTALLATION	20
FAN ACCESSORY	20
OPERATION OF THE FIREPLACE	20
Advantages Of A Wood Burning Fireplace	20
Which Woods Are Best?	21
How To Build A Better Fire	21
Wood vs. Fossil Fuels	21
A Few Words Of Caution	22
Fuel Storage	22
Disposal Of Ashes	22
FIREPLACE AND CHIMNEY MAINTENANCE	22
Chimney Maintenance	22
Fireplace Maintenance	22
GLASS DOOR MAINTENANCE	22
CHECKLIST OF DO'S AND DON'TS	25

IMPORTANT NOTICES

THESE FIREPLACE MODELS ARE LISTED BY UNDERWRITERS LABORATORIES, INC. TO U.L. 127-STANDARD FOR FACTORY-BUILT FIREPLACES. THE DESIGN OF THIS FIREPLACE AND THESE INSTRUCTIONS COMPLIED WITH APPLICABLE SAFETY STANDARDS FOR A FACTORY BUILT FIREPLACE IN EFFECT AT THE TIME THE FIREPLACE WAS MANUFACTURED. YOU SHOULD BE AWARE, HOWEVER, THAT FAILURE TO INSTALL, OPERATE, AND MAINTAIN THIS OR ANY OTHER FACTORY BUILT FIREPLACE PROPERLY CAN RESULT IN A HOUSE FIRE OR OTHER OCCURRENCES THAT COULD CAUSE DEATHS, INJURIES, AND PROPERTY DAMAGES. IT IS VERY IMPORTANT THAT THE PERSONS INSTALLING AND/OR SUPERVISING THE INSTALLATION OF THIS FIREPLACE HAVE APPROPRIATE SKILLS IN USING THE TOOLS AND TECHNIQUES REQUIRED; AND READING AND COMPREHENSION SKILLS SUFFICIENT TO READ AND FOLLOW THESE INSTRUCTIONS. THESE INSTRUCTIONS CONTAIN WARNINGS, CAUTIONS, AND NOTES TO EMPHASIZE IMPORTANT SAFETY INFORMATION. TO ASSURE THAT SAFE AND SATISFACTORY SERVICE IS RECEIVED FROM THIS FIREPLACE, PLEASE READ THE FOLLOWING SPECIAL NOTICES AND ALL THE CONTENTS OF THIS MANUAL.

1. Read these instructions entirely before beginning any part of the installation. Save these instructions for any future repairs.
2. Use these instructions as a guide during the installation of the fireplace.
3. Be sure these instructions become the property of and are reviewed by all future users of this fireplace to encourage proper operation and maintenance.
4. All the parts used with this fireplace system must be installed in accordance with these installation instructions. Failure to do so may be hazardous and will void the warranty.
5. This fireplace and accessories should not be altered in any way that is not specifically recommended in this manual.
6. Refer to your local building code for local requirements pertaining to the installation of factory-built fireplaces. Martin fireplaces are intended for installation and use according to standard NFPA No. 211 of the National Fire Protection Association.
7. This fireplace must not be installed with a masonry flue.
8. This fireplace and chimney should not be used for venting a wood or coal burning heater or fireplace insert.
9. **WARNING: DO NOT PACK REQUIRED AIR SPACES WITH INSULATION OR OTHER MATERIALS.**

INTENDED PRODUCT USAGE

The fireplace is designed to sit directly on a combustible floor. The fireplace can also be installed with zero clearance to combustible building materials at the side, back and top spacers. Only parts manufactured by Martin Industries and labeled for use

with the fireplace should be used in the installation of this fireplace except for special roof flashings that may be fabricated locally. The use of improper parts in the installation can be hazardous and voids the warranty offered by Martin Industries.

This fireplace is designed to burn wood. This fireplace is not designed to burn coal, unplumbed liquid fuels, unplumbed gaseous fuels or household refuse. Any attempt to burn these fuels in the fireplace can be hazardous.

This fireplace is not designed for installation in a mobile home.

WARNING: This fireplace and chimney must not be used for venting a solid fuel heater or fireplace insert unless written authorization is given by Martin Industries. Failure to heed this warning may cause a fire hazard and will void the Martin Warranty.

This fireplace is intended for supplemental heating only and is not intended for use as a primary heating system.

"USE SOLID WOOD, PLUMBED PROPANE (LP) OR NATURAL GAS FUEL ONLY."

"DO NOT USE A FIREPLACE INSERT OR OTHER PRODUCT NOT SPECIFIED FOR USE WITH THIS FIREPLACE."

IMPROPER INSTALLATION

Improper installation or use of this fireplace will void the warranty and can cause:

1. Damage to the fireplace from overheating.
2. Hazardous temperatures to develop on combustible materials adjacent to the fireplace or chimney.
3. The emission of smoke, sparks or hazardous gases into the dwelling.
4. Leakage of rain water into the dwelling.

HOW THIS FIREPLACE OPERATES

As wood is burned in the fireplace, room air enters the lower louvered panel of the model SC36 or the slot beneath the hearth of the model SA36 and circulates around the firebox. This air circulation cools the firebox and must not be blocked or restricted in any manner. Blocking the air flow can cause a fire hazard.

When a AK-4 combustion air assembly and a combustion air duct are attached to the connecting point on the left of the fireplace, combustion air may enter the firebox through a dampered opening behind the left side panel. This feature is designed for your benefit to reduce the room air used for combustion and to prevent excessive loss of heat from the room. When the fireplace is in use, this damper should be open. When the fireplace is not in use, the damper should be closed to prevent cold air from entering the firebox. The combustion air damper is open when the lever, located on the left side of the firebox near the top of the left firebrick, is up and closed when the lever is down.

Outside air for combustion is optional unless required by federal, state or local building codes. See the section of this manual providing the instructions for installation of the combustion air assembly.

The design of the fireplace allows the routing of the combustion air duct downward or horizontally to obtain the outside combustion air. This permits flexibility in planning your installation. See figure 25 for typical installation methods. Be sure to review the precautions and recommendations in the section of this manual pertaining to outside combustion air installation.

Glass doors should be installed to receive the maximum benefit from your fireplace. For large fires, the maximum heating benefit from the fireplace will be obtained with the doors open due to the high amount of radiant heat being emitted out of the front opening of the fireplace. With a small fire, it is best to operate the fireplace with the doors closed to prevent excessive room air from being drawn up the chimney. Before retiring in the evenings, the doors should be closed to prevent excessive room air from escaping up the chimney. When the doors are open the mesh screens should be closed to help keep burning embers from popping out of the firebox.

The fireplaces are equipped with a flue damper which must be open when the fireplace is in use. The flue damper control lever is located behind the upper panel and is locked closed by turning the damper lever and latching it over the clip provided. When the fireplace is not in use, the damper should be closed to prevent cold air from entering the chimney as well as preventing warm air in the room from escaping up the chimney.

NOTE: It is normal for a small amount of smoke to be released from the upper portion of the fireplace the first few times you use your new Martin fireplace. This results from an oil residue on the metal. Open a door or window to allow the smoke to escape.

The grate included with this fireplace helps to appropriately locate and contain the burning wood. Failure to use this grate may cause overheating of parts of the fireplace and allow large pieces of burning wood to roll forward out of the firebox. If the grate becomes warped or damaged, it must be replaced with Martin grate number 031899 only.

WARNING: FIREPLACES EQUIPPED WITH DOORS SHOULD BE OPERATED ONLY WITH DOORS FULLY OPEN OR DOORS FULLY CLOSED. IF DOORS ARE LEFT PARTLY OPEN, GAS AND FLAME MAY BE DRAWN OUT OF THE FIREPLACE OPENING, CREATING RISKS OF BOTH FIRE AND SMOKE.

All fireplace chimneys are in direct contact with cold air on the exterior of the structure. Consequently, when the fireplace is not in use, cold air can fall down the chimney of the fireplace and cool off the fireplace chase. Therefore, the fireplace chase must be insulated to minimize the risk of cold air infiltration into the home. Even if the fireplace chase is adequately insulated, this cannot completely insure that cold air infiltration into the structure will be eliminated. Cold air infiltration is a possibility with any fireplace or device that freely communicates with the air on the outside of the structure. Today's homes are more energy efficient and, therefore, better insulated and tightly constructed. Unfortunately, when air is removed from the house, as by a bathroom fan, or consumed by a furnace, additional air is needed to replace the air consumed. Unless the additional air is supplied, this can cause a negative pressure in the home. When this happens, the house will draw in outside air from the cracks in the

windows, down the fireplace flue or other locations of air leakage in the home. Because cold air infiltration may be unavoidable in some structures, Martin Industries is not responsible for heat loss or air infiltration through or around the fireplace.

BUILDING CODES AND SAFETY REQUIREMENTS

The instructions contained in this manual provide the information necessary to install this fireplace in accordance with Underwriters Laboratories requirements and in compliance with the National Fire Protection Association Standard No. 211. Some codes may require the fireplace and chimney be electrically grounded. Before beginning the installation, you should check with local building officials to obtain required permits and assure compliance with local regulations and codes. If you encounter problems with code requirements, contact your Martin dealer for assistance.

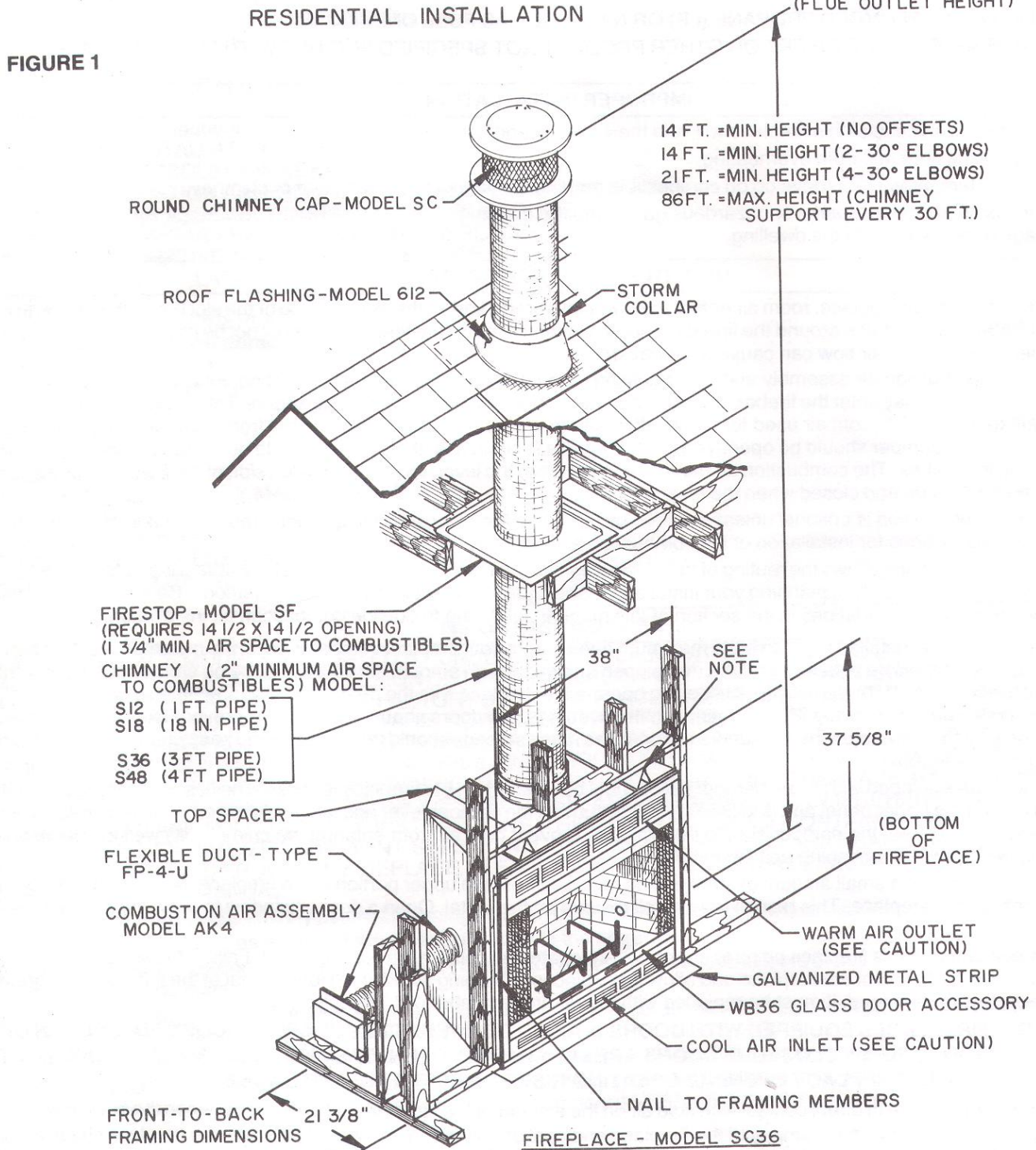

CAUTION: DO NOT BLOCK AIR INLETS OR OUTLETS.

NOTE: COMBUSTIBLE MATERIALS SHOULD NOT BE INSTALLED BELOW TOP SPACER. NON-COMBUSTIBLE MATERIALS SUCH AS BRICK OR TILE MAY BE USED TO TRIM FACE OF THE FIREPLACE BUT SHOULD NOT COVER ANY PORTION OF THE LOUVERED PANEL OR COOL AIR INLET. COMBUSTIBLES MUST NOT OVERLAP THE BLACK PAINTED FACE OF FIREPLACE.

FIGURE 2

“S” SERIES FIREPLACE COMPONENTS

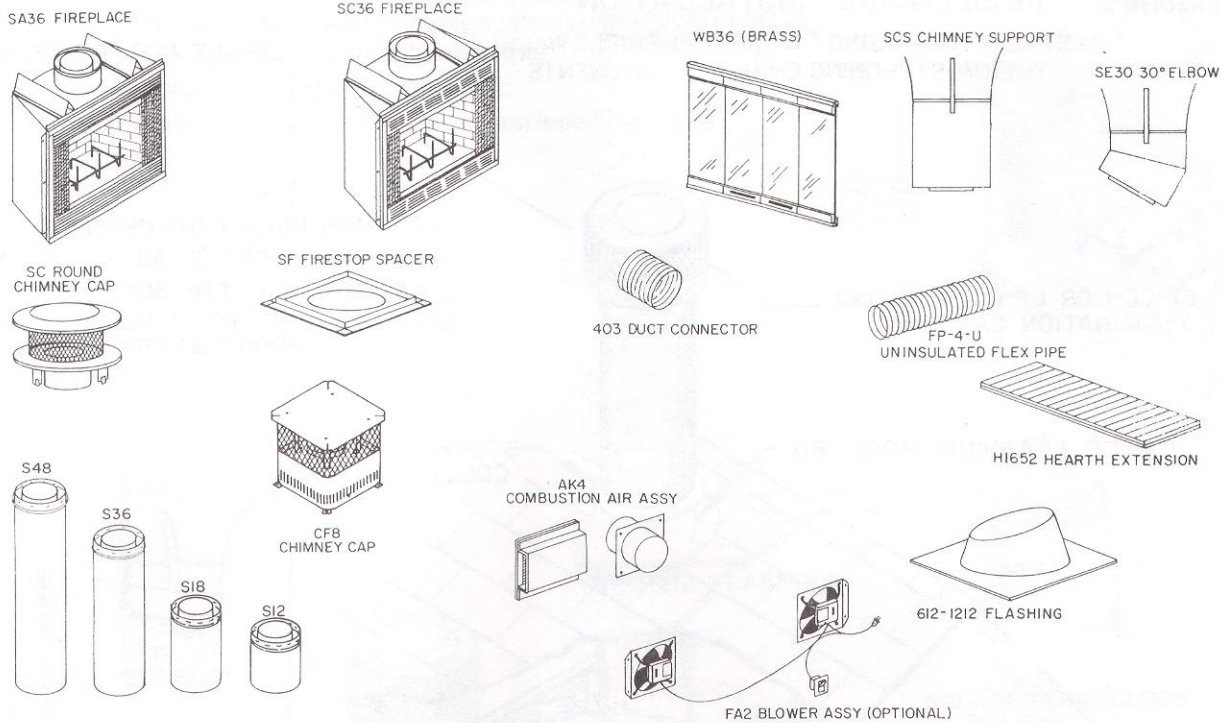

MODEL NUMBER	DESCRIPTION
SC36 - SA36	36-inch front opening fireplace. Includes wire firescreen, sealing flue damper and outside combustion air capability. When installed, outside combustion air can be connected to left side. See installation instruction for details.
S48	4 foot chimney section (8 inch diameter flue).
S36	3 foot chimney section (8 inch diameter flue).
S18	1 1/2" foot chimney section (8 inch diameter flue).
S12	1 foot chimney section (8 inch diameter flue.)
SE30	30 degree elbows (package contains two 8 inch diameter elbows). One pair is required for each offset. Maximum--two pairs (4 elbows per chimney).
SCS	Chimney support (required when chimney height exceeds 30 feet).
SC	Round chimney cap for contemporary installation, includes storm collar.
SCL	Round telescoping chimney cap.
SQL8	Square telescoping chimney cap.
612	0-6/12 pitch flashing for contemporary installation. One required with SC round chimney cap on 0-6/12 pitch roof.
CF8	Terra Cotta style chimney cap for chase top installation.
1212	6/12-12/12 pitch flashing for contemporary installation. One required with SC round chimney cap on 6/12-12/12 pitch roof.
SF	14 1/2" inch firestop spacer--One required at each ceiling or floor level.
SF-30	Firestop spacer - for 30° chimney incline through ceiling or floor.
FP-4-U	4" uninsulated combustion air duct--8 foot lengths.
403	4" Duct connector (for splicing FP-4 ducts, includes one connector and two clamps.)
AK4	4" Outside combustion air assembly.
WB36	Optional 36 inch polished brass glass door kit.
FA2	Optional fan assembly--includes switch. Installs under fireplace by removing lower grille panel of fireplace. (SC36 Only).
H1652	Hearth extension--protects floor against sparks and radiant heat. Residential installation.) 16" x 52".
JB1	Junction Box-For Optional Blower Assembly Installation. Must be installed at the time of fireplace installation if the model FA2 Fan is to be installed. (SC36 only).
S8	Telescope assembly for use with telescoping chimney caps.

FIGURE 3 RESIDENTIAL INSTALLATION
INSTALLATION USING "E" SERIES TRIPLE WALL
THERMOSYPHONING CHIMNEY COMPONENTS

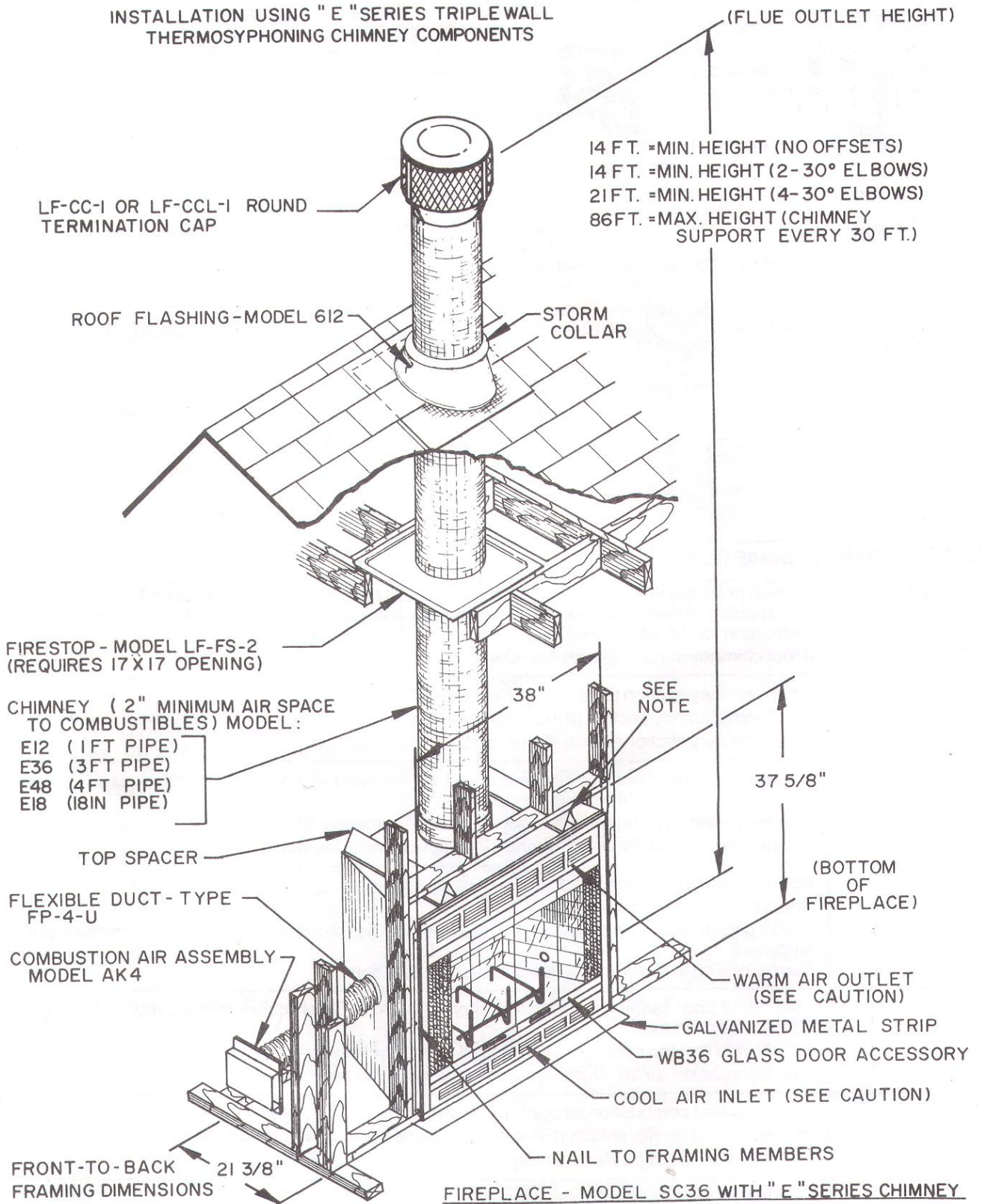

CAUTION: DO NOT BLOCK AIR INLETS OR OUTLETS.

NOTE: COMBUSTIBLE MATERIALS SHOULD NOT BE INSTALLED BELOW TOP SPACER. NON-COMBUSTIBLE MATERIALS SUCH AS BRICK OR TILE MAY BE USED TO TRIM FACE OF THE FIREPLACE BUT SHOULD NOT COVER ANY PORTION OF THE LOUVERED PANEL OR COOL AIR INLET. COMBUSTIBLES MUST NOT OVERLAP THE BLACK PAINTED FACE OF FIREPLACE.

"E" Series Triple-Wall Chimney System Installation Only. (Pages 6 & 7)

INSTALLATION INSTRUCTIONS AND PRECAUTIONS

1. When installing "E" series triple wall chimney system on the SA36 or SC36 do not mix chimney system components other than those listed below.
2. Maintain 2" airspace clearance to combustibles.
3. Use same offset and rise chart for chimney when installing elbows.

FIGURE 4

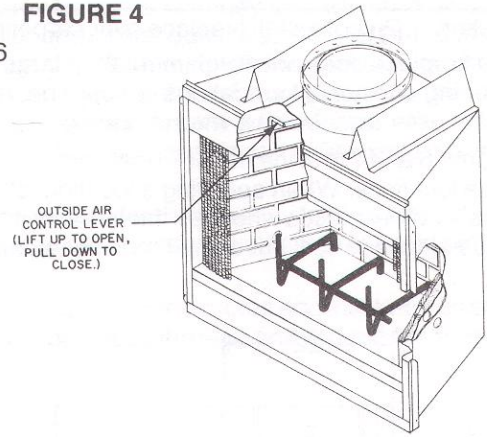
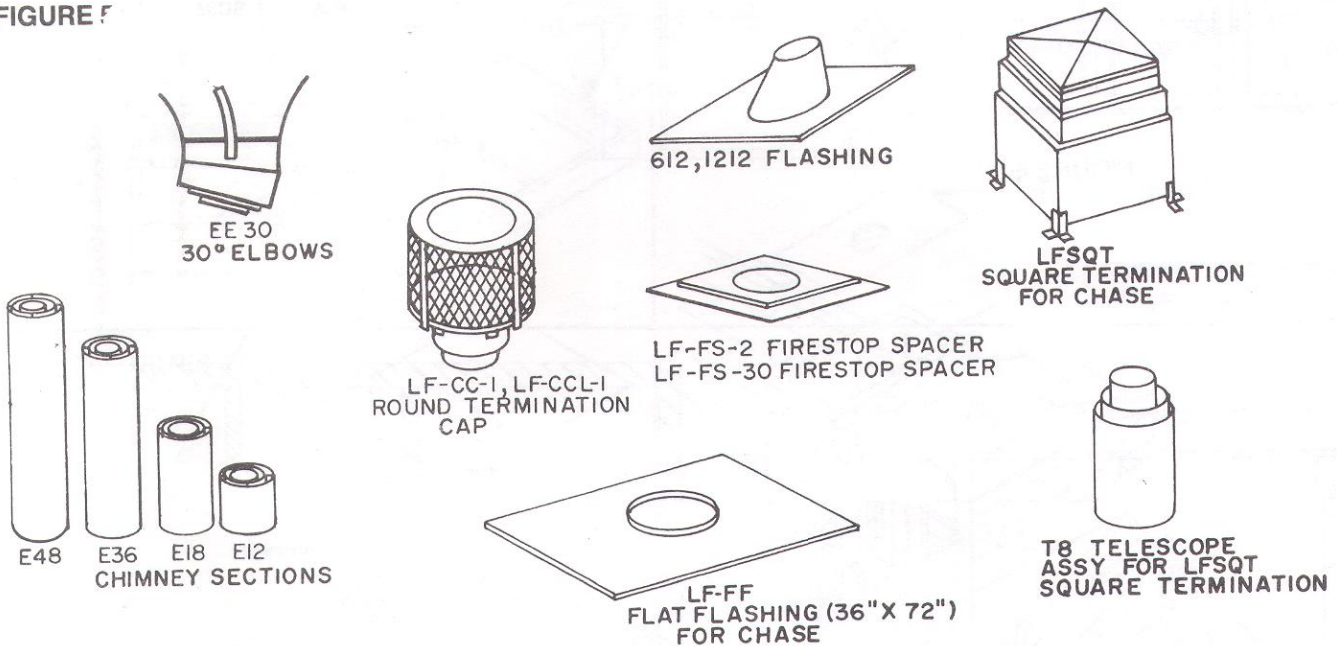

FIGURE 5



E48	4 foot chimney section (8 inch dia.)
E36	3 foot chimney section (8 inch diameter).
E18	18" foot chimney section (8 inch diameter).
E12	1 foot chimney section (8 inch diameter).
EE30	30 degree elbows (package contains two 8 inch diameter elbows). One pair is required for each offset. Maximum--two pairs (4 elbows per chimney).
ECS	Chimney support (required when chimney height exceeds 52 feet).
LFCC-1	Round termination cap for contemporary installation, includes storm collar.
LFCC-1	Round termination cap for chase installation (includes inlet air telescope).
612	0-6/12 pitch flashing for contemporary install. One required with LFCC-1 round termination cap on 0-6/12 pitch roof.
1212	6/12-12/12 pitch flashing for contemporary installation. One required with LFCC-1 round termination cap on 6/12-12/12 pitch roof.
LF-FS-2	17" firestop spacer--One required at each ceiling or floor level below 20 foot chimney height.
LF-FS-30	Firestop spacer--for 30° chimney incline through ceiling or floor.
LFSQT	Square termination for chase installation. Model T8 telescope assembly required but not included.
T8	Telescope assembly for use with LFSQT square termination.
LF-FF	Flat flashing for chase installation (36" X 72").

"E" Series Triple-Wall Chimney System Installation Only. (Pages 6 & 7)

SELECTING A LOCATION

Caution: Do not install fireplace over carpeting.

This fireplace does not weigh more than large pieces of furniture and can normally be locate near a load bearing wall without requiring additional foundations or supports. If, however, the fireplace is to be trimmed with a heavy stone or brick facing and hearth extension, be sure the supporting structure is adequate.

Figures 6 and 7 provide dimensional details of the fireplace, required spacing to combustibles walls, and some suggested fire-place locations. When selecting a location, choose one that is away from frequently opened doors, central heat outlets or re-turms, or other places where air movements may disturb the air flow around the fireplace. Air turbulence near the fireplace may cause smoke to spill out of the fireplace opening.

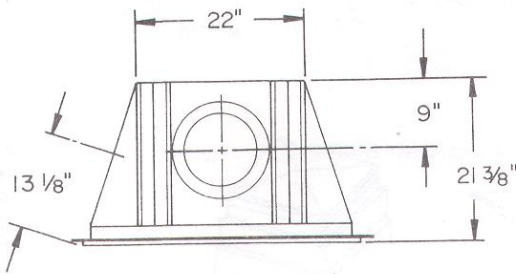

FIGURE 6

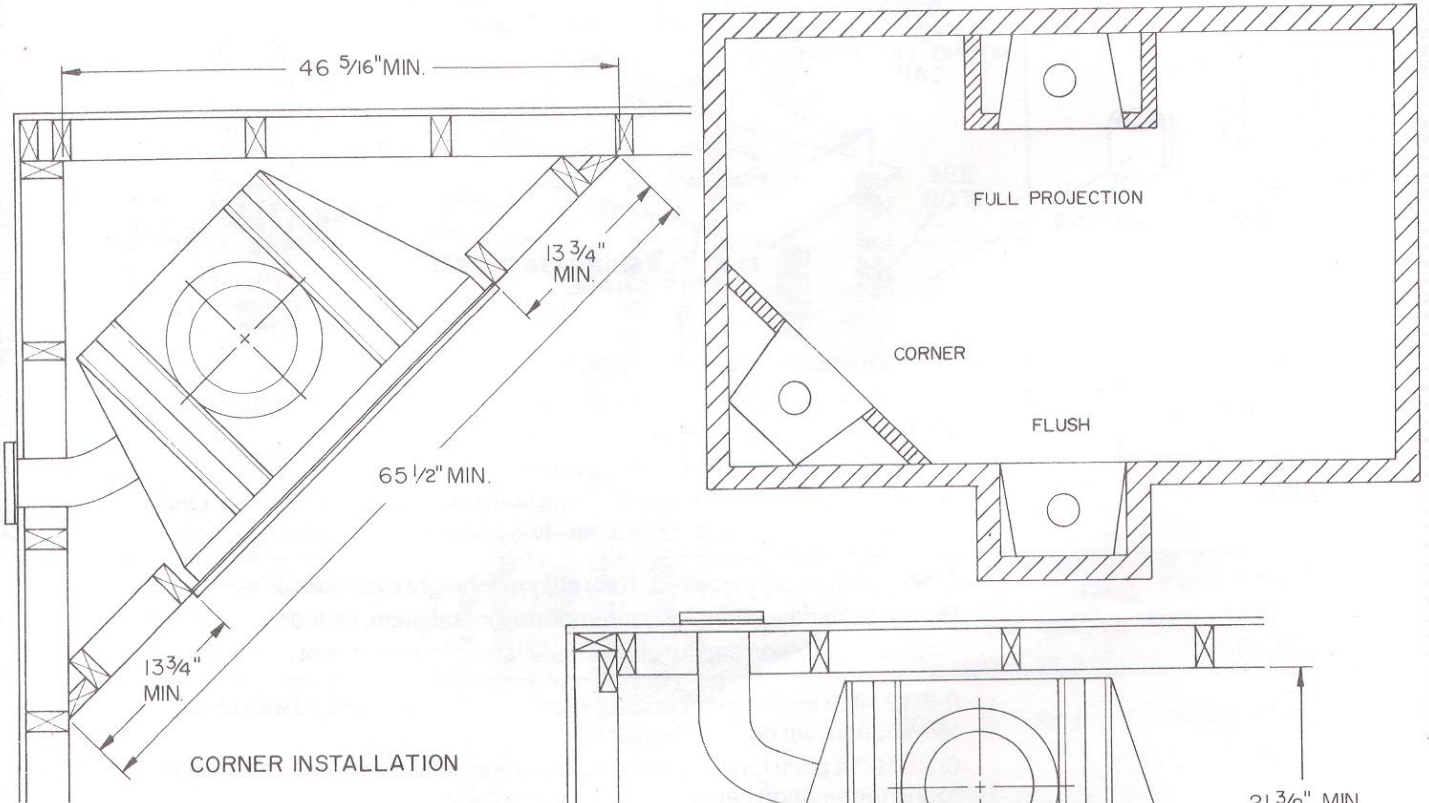
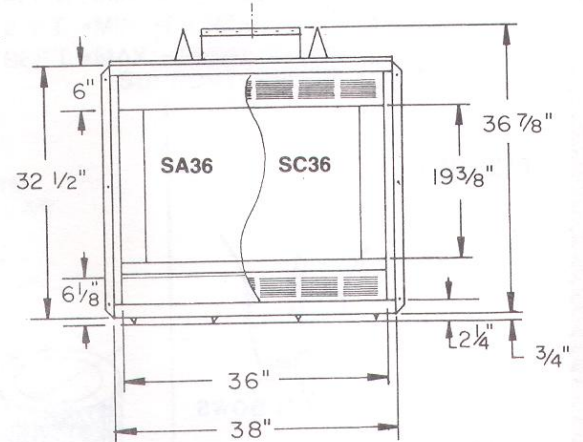
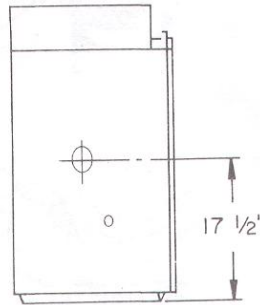

FIGURE 7

NOTE: Combustible sidewall clearance may be reduced by 12" if the fireplace is provided with the WB36 glass door assembly.

Survey the planned location for the fireplace for overhead plumbing or electrical wires etc., that might complicate the installation or endanger persons installing or cleaning the chimney. Avoid a location where the chimney cap will be near abrupt changes in the roof shape, nearby walls or embankments, under or near trees or above the roof of a single story wing of a two story building as shown by figure 11. All these conditions can cause turbulence or pressure conditions that can cause poor chimney draft and smoke spillage from the fireplace opening. Elbows may be used to offset the chimney to avoid obstructions or to locate the chimney cap in a preferred location. Refer to the sections of this manual pertaining to chimney offsets for instructions on proper elbow use. Poor installation or location of the chimney cap and/or components can cause wind blown rain to enter the chimney.

Be sure the selected location will allow a 14 1/2" square combustible material free space for the chimney to pass through. If the chimney is to pass through living or storage spaces be sure there is adequate space to enclose the chimney to avoid personal contact with or damage to the chimney.

If the fireplace is to be installed on an outside wall, the surrounding walls (chase) should be constructed and insulated as shown by figure 8. Failure to insulate the fireplace from outside temperatures will cause heat loss through and around the fireplace.

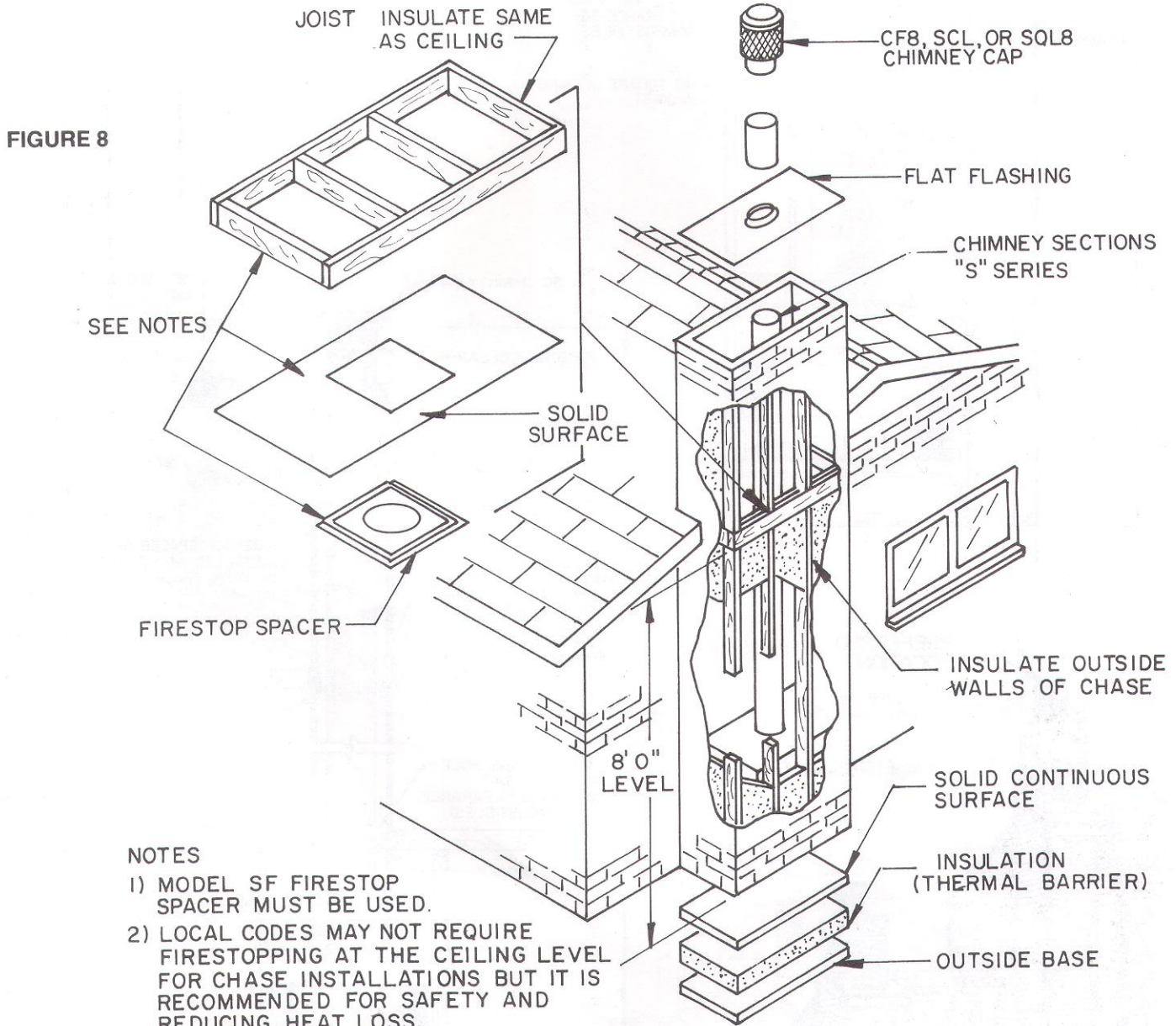
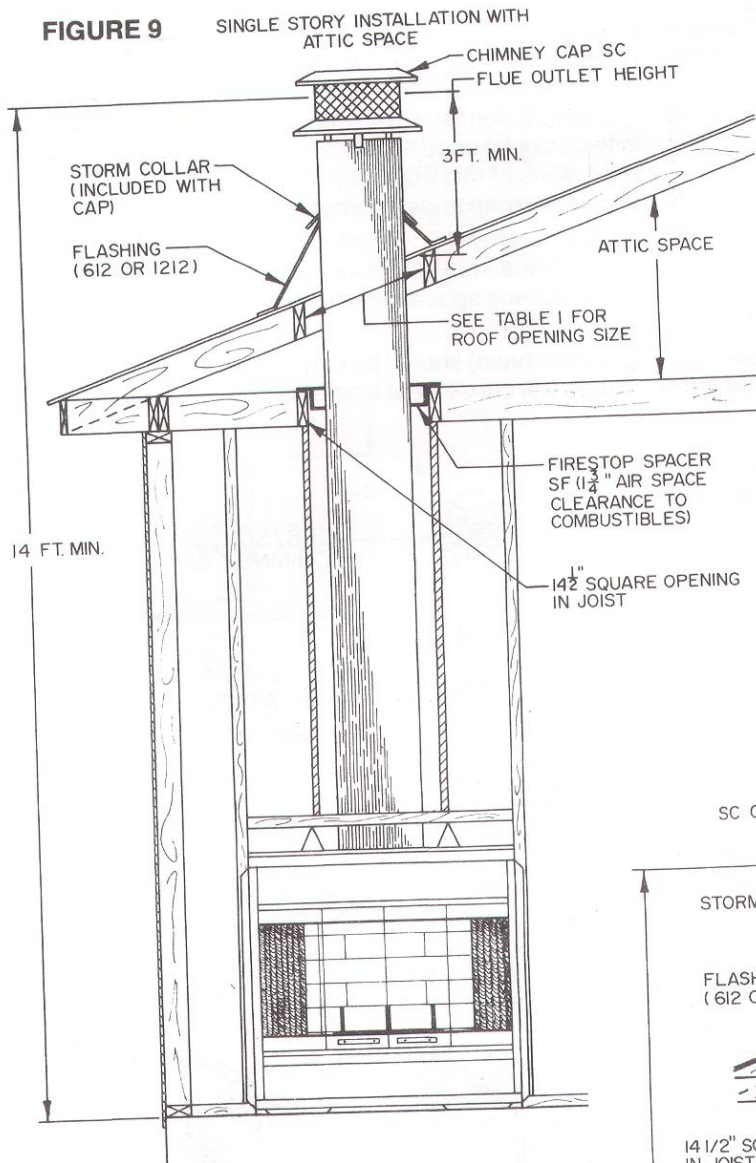
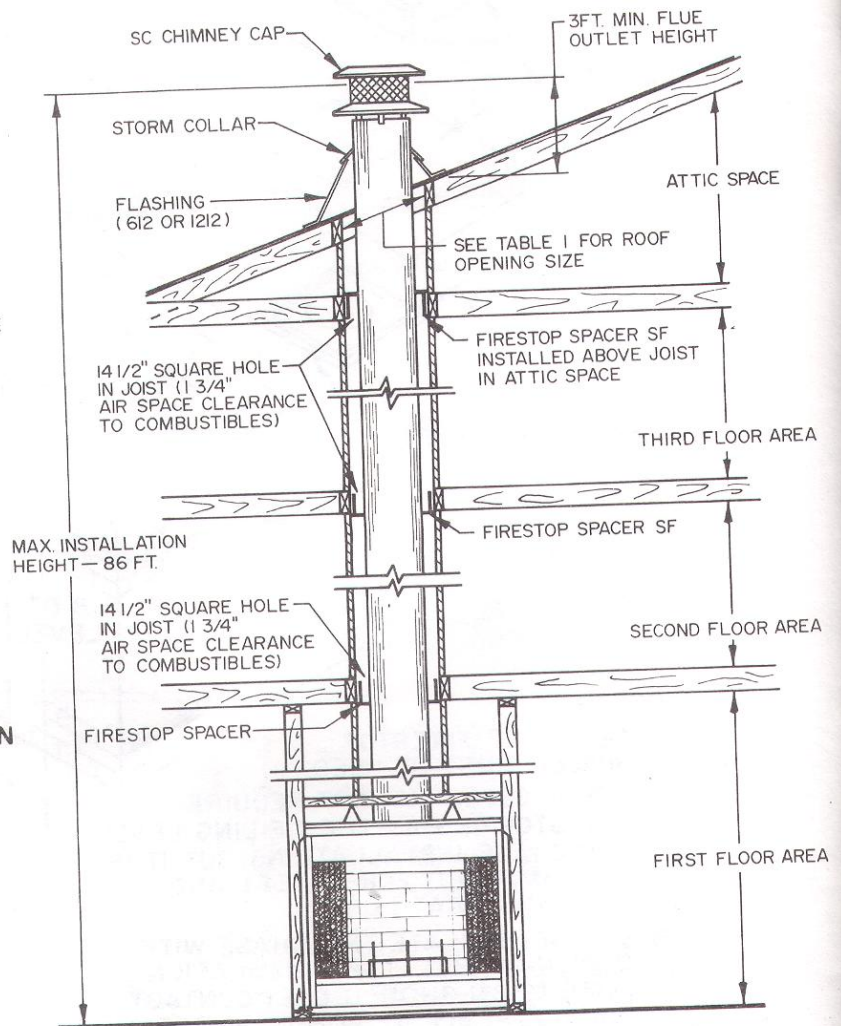

FIGURE 9



14 FT. MIN.

FIGURE 10
MULTIPLE STORY INSTALLATION



MAX. INSTALLATION HEIGHT - 86 FT.

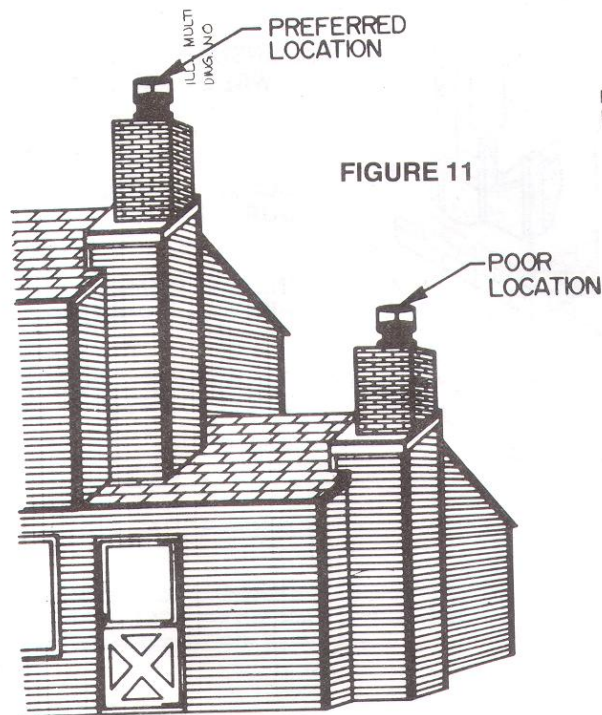

FIGURE 11

FLOOR PROTECTION

If this fireplace is installed on a combustible floor, the floor area 16 inches in front of and 8 inches either side of the fireplace opening must be protected by an insulating non-combustible hearth extension. This hearth extension may be either minimum 6 inch thick stone or brick as shown by figure 12, a Martin H1652 Hearth Extension Kit, or a locally constructed equivalent which has a "K" factor less than .43.

FIGURE 12

ALTERNATE BRICK OR STONE HEARTH EXTENSIONS FOR USE WITH THE SA36 FIREPLACE

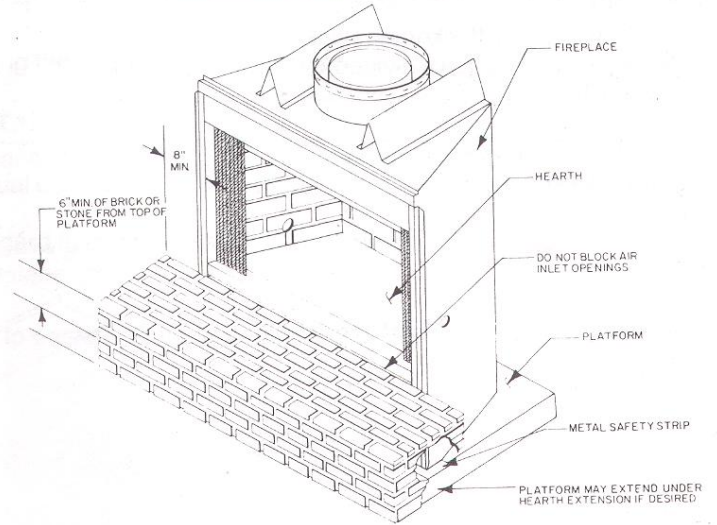

ALTERNATE BRICK OR STONE HEARTH EXTENSIONS FOR USE WITH THE SA36 FIREPLACE

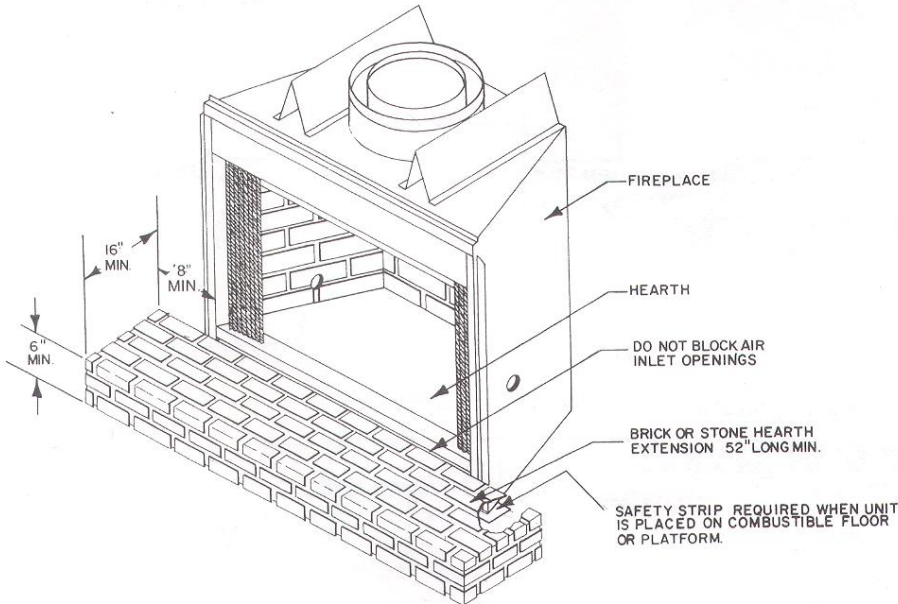

ALTERNATE BRICK OR STONE HEARTH EXTENSIONS FOR USE WITH THE SA36 FIREPLACE

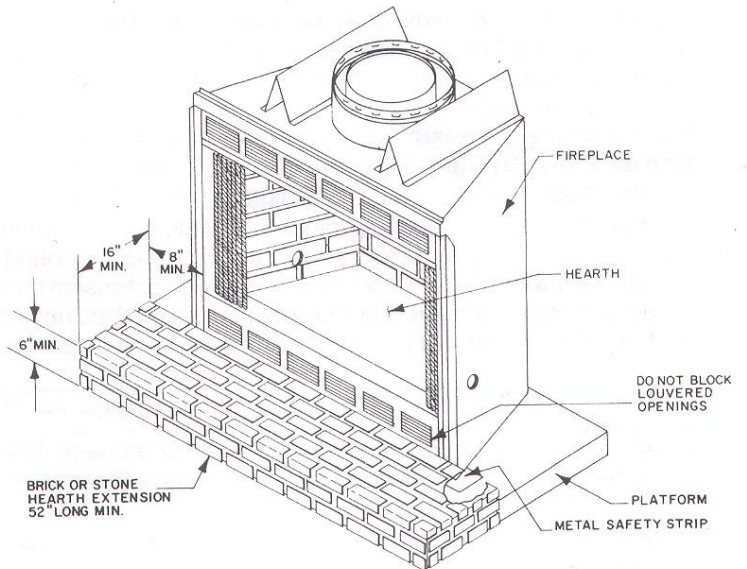

The ability of insulating material to retard the transfer of heat may be expressed as either Thermal conductance (C), Thermal Conductivity (K), or Thermal Resistance (R). The mathematical relationship of these values and the formulas for converting one value to another is as follows:

$C = K$ divided by the material thickness.

(Example $C = .43$ divided by $1/2$ (.50)

$C = .86$)

$K = C$ multiplied by the material thickness.

(Example $K = .86$ multiplied by $1/2$ (.50)

$K = .43$)

$R =$ The material thickness divided by K

(Example $R = 1/2$ (.50) divided by $.43$

$R = 1.16$)

FIGURE 13

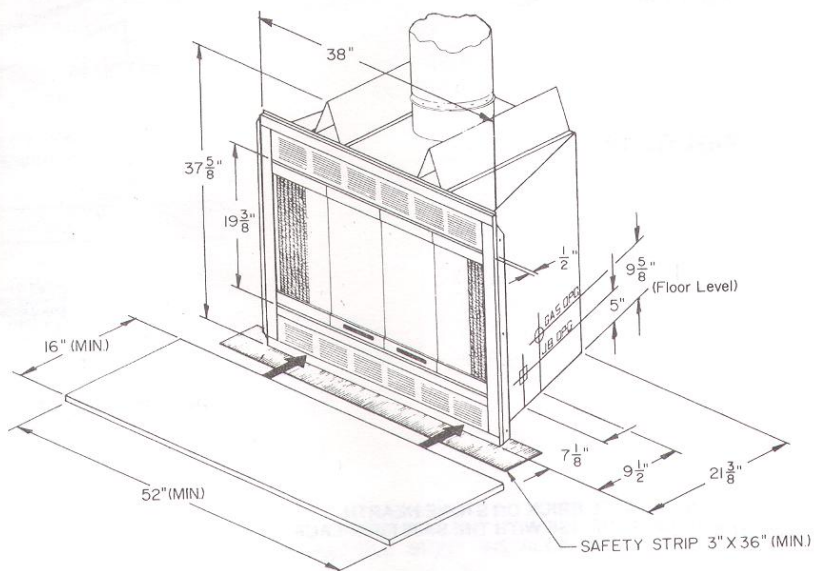

WARNING: THE HEARTH EXTENSION AND THE GALVANIZED METAL STRIP SHOULD BE INSTALLED ONLY IN A HORIZONTAL RELATIONSHIP TO THE FIREPLACE, AS ILLUSTRATED.

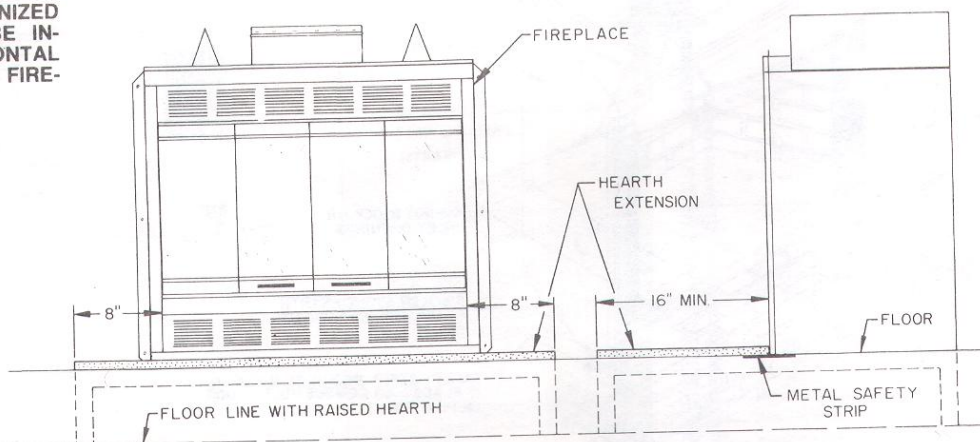

With any type hearth extension minor shifting of the supporting floor or expansion and contraction may eventually cause a crack to develop between the hearth extension and the face of the fireplace. To help prevent the crack from developing, the hearth extension material must be firmly fastened in place. Wall ties should be screwed to the face of the fireplace and imbedded in the mortar joints of brick, stone, or other non-combustible materials. **The metal safety strip packed with the fireplace must be placed beneath the fireplace and extend under the hearth extension or into a mortar joint of the hearth extension as shown by figures 12 and 13.** In the event a crack does eventually develop, the metal safety strip will serve as a barrier to prevent sparks or embers from falling from the fireplace onto combustible flooring materials.

The hearth extension **must not** block the air slot or air inlet louvers on the lower front of the fireplace. These openings must be unobstructed to assure an adequate flow of cooling air around the firebox. If the model SC36 is equipped with a blower, or may be equipped with one at a later date, the hearth extension must not prevent the removal of the lower louver panel for servicing the blower. Plan adequately by determining the finished height of the hearth extension to be used and elevate the fireplace on a platform, if necessary, to prevent obstructing the air openings or lower louvered panel.

INSPECTION OF FIREPLACE COMPONENTS

Unpack and check the fireplace and chimney for damage. If any items have been damaged, report this to your Martin dealer. Before beginning the installation, be sure you have the proper parts in sufficient quantity. Refer to figure 2 for proper identification of parts.

DO NOT SUBSTITUTE PARTS. USE ONLY PARTS LISTED FOR USE WITH THE MARTIN MODEL SA36 AND SC36 FIREPLACES.

FIREPLACE INSTALLATION

1. Refer to figure 1 for an example of a typical installation of the fireplace components.
2. Be sure the location of the fireplace will provide the required clearances indicated by figures 7, 9, and 10 and the minimum chimney air space clearance to combustibles of two inches.
3. Set the fireplace in the desired location and be sure it is securely supported and leveled. Check the face of the fireplace with a carpenter's level and if it is not plumb, correct it by placing shims under the edges of the fireplace.
4. Block in the fireplace to prevent any shifting of the firebox. Secure the fireplace with nails or screws through the flanges located on each side of the fireplace. Do not enclose the fireplace until the combustion air duct and chimney pipes are installed. (See figure 1.)

NOTE: Some local codes may require electrically grounding the fireplace and chimney.

CHIMNEY INSTALLATION

In order to assure safe and satisfactory performance of the fireplace, it is very important to properly install the chimney. This is an important part of the installation and the sections of this manual pertaining to chimney installation should be reviewed very thoroughly.

For your safety, some of the important things to remember in regard to chimneys are listed below:

1. Use only parts and accessories labeled for use with this fireplace.
2. Use only undamaged parts and accessories.
3. Enclose the chimney where it passes through living spaces to prevent contact with and possible damage to the chimney.

FIGURE 14

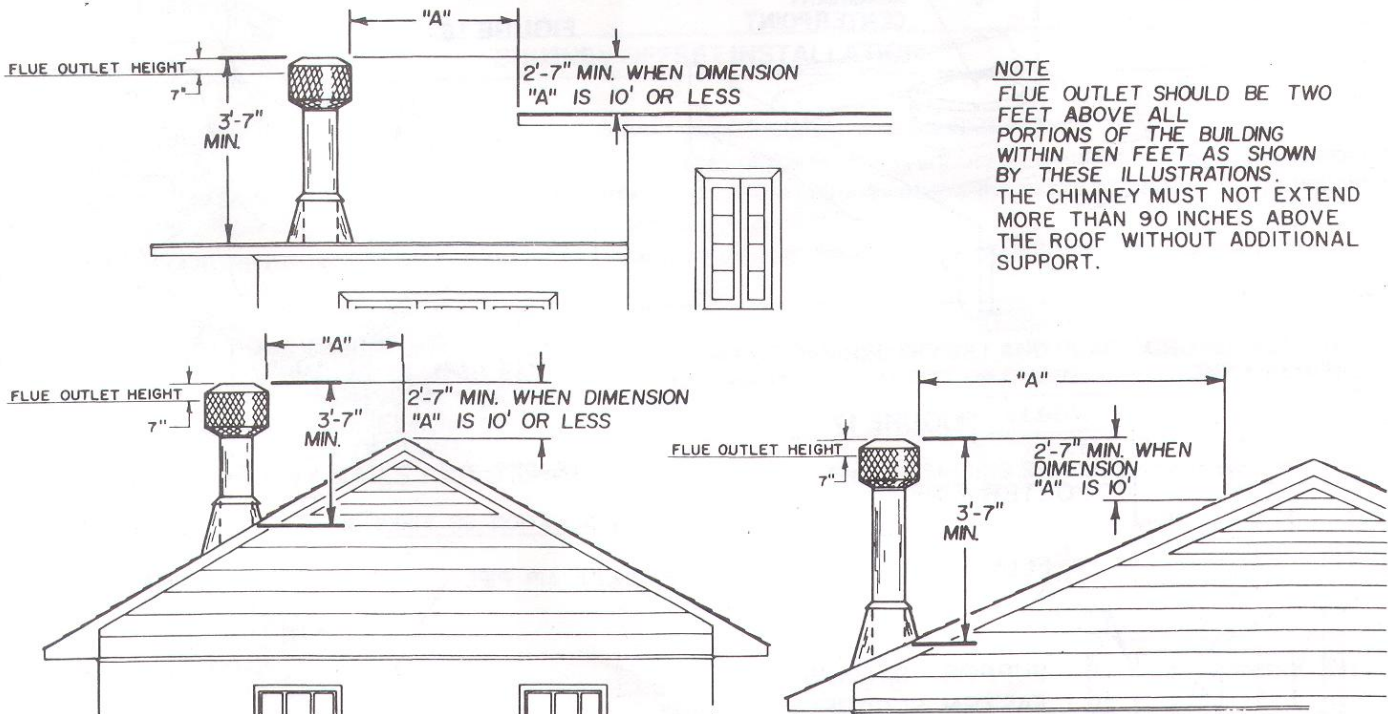

4. Install firestop spacers at each ceiling level.
5. Install the proper chimney cap or chimney housing on the chimney to prevent the entry of rain and debris into the chimney and to assure proper venting of the smoke.
6. Do not use more than four elbows in the chimney.

NOTE: To select the proper chimney height, refer to figure 1. The flue outlet must be a minimum of three feet above the highest point where the chimney penetrates the roof and a minimum of two feet above all portions of the building within ten feet. (See figure 14.) If the chimney is to include elbows to offset the chimney, refer to the next section of this manual. There must be at least two inches air space between all sections of the chimney and combustible materials between floors.

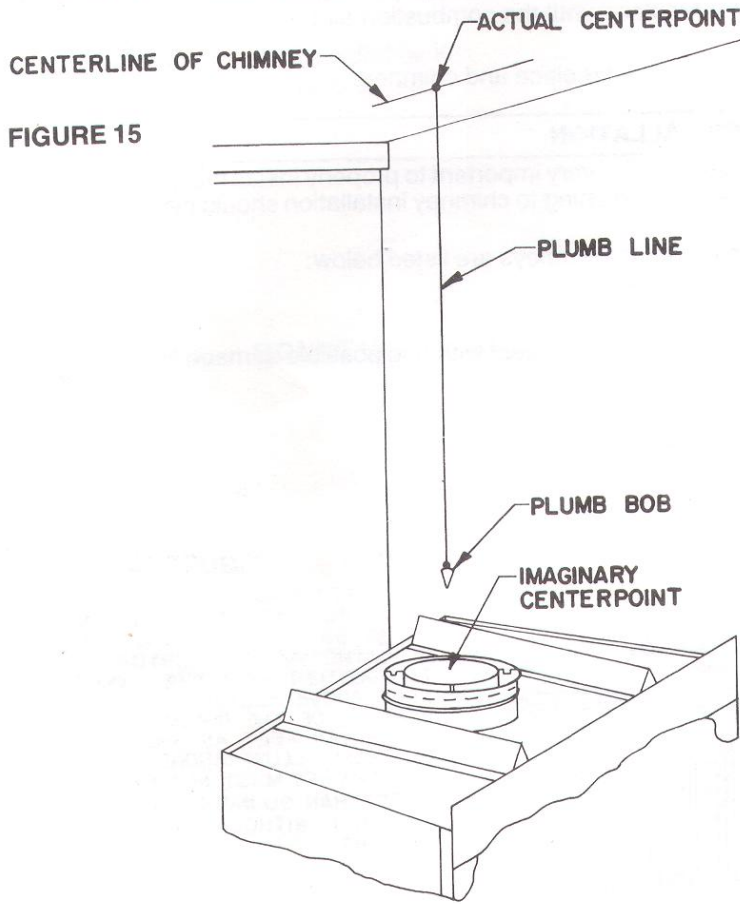
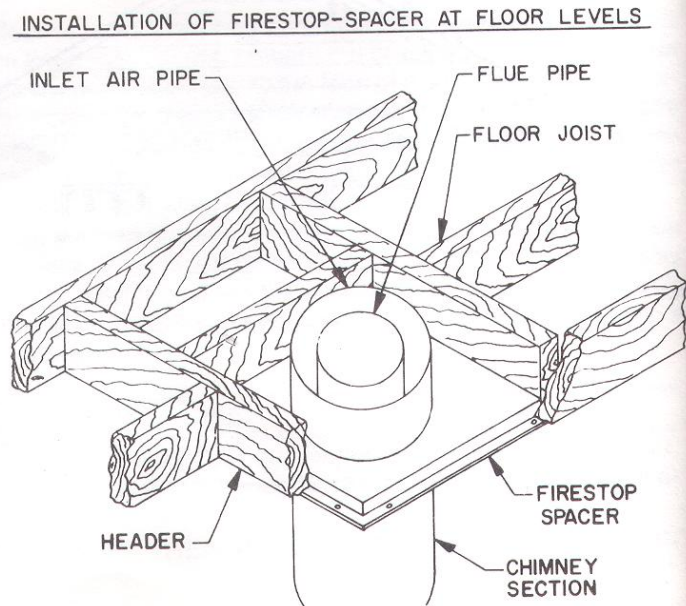
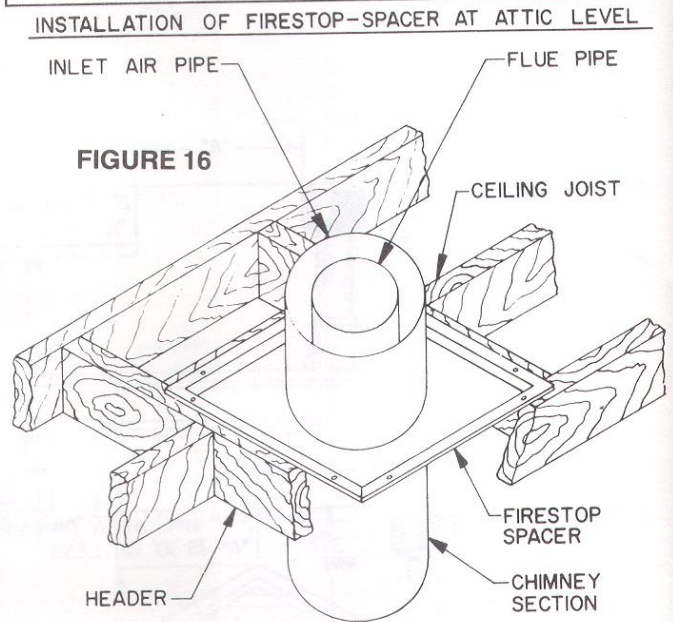
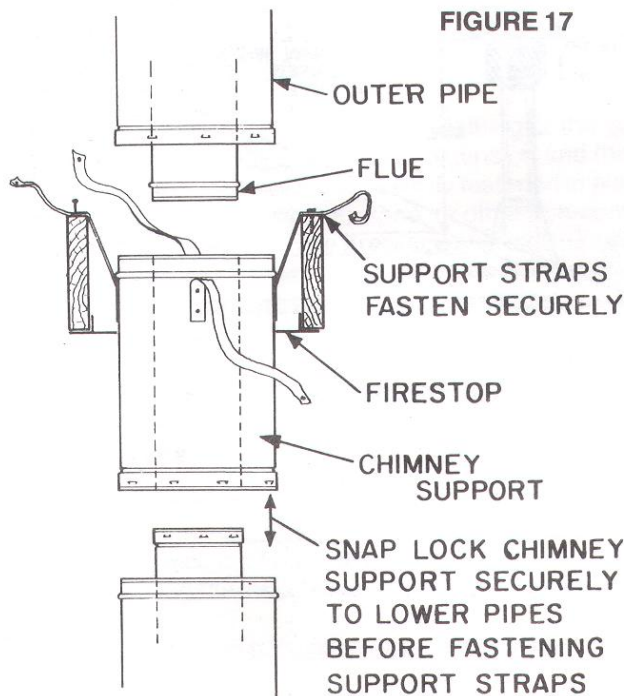

Table 1
MINIMUM REQUIRED ROOF OPENING
MINIMUM FRAMED OPENINGS

ROOF PITCH	"S" SERIES	"E" SERIES
	DOUBLE WALL CHIMNEY	TRIPLE WALL CHIMNEY
0/12	14 1/2" x 14 1/2"	17" x 17"
1/12	14 1/2" x 14 5/8"	17" x 17 1/8"
2/12	14 1/2" x 14 3/4"	17" x 17 1/4"
3/12	14 1/2" x 15"	17" x 17 1/2"
4/12	14 1/2" x 15 1/4"	17" x 17 3/4"
5/12	14 1/2" x 15 3/4"	17" x 18 1/4"
6/12	14 1/2" x 16 1/4"	17" x 18 3/4"
7/12	14 1/2" x 16 7/8"	17" x 19 3/8"
8/12	14 1/2" x 17 1/2"	17" x 20"
9/12	14 1/2" x 18 1/8"	17" x 20 5/8"
10/12	14 1/2" x 18 7/8"	17" x 21 3/8"
11/12	14 1/2" x 19 3/4"	17" x 22 1/4"
12/12	14 1/2" x 20 1/2"	17" x 23"



1. Lay out, cut and frame openings through all ceilings and the roof at the point where the chimney will pass through. Unless the chimney is to be offset, the point where the center line of the chimney will pass through the ceiling and roof can be determined with a plumb line as shown by figure 15. The fireplace should be located in the planned installation position. After the center line is established and a nail is driven to mark the point, the opening can be cut if you are satisfied with the chimney location relative to ceiling and roof joists and/or any other obstructions. The roof opening center line should be marked by driving a nail through the roof from underneath that will penetrate the roof and can be located from the rooftop. If the chimney is to penetrate a pitched roof, the hole in the roof must be rectangular instead of square and should be sized according to table 1.
2. Install the firestop spacer as required from beneath the ceiling unless the space above is attic space. In an attic, the firestop spacer should be installed at the floor level of the attic (see figure 16). You must have joist or headers on all four sides of the spacer and use a minimum of four 8 penny nails to secure the spacer.
3. To install the "S" series chimney sections, insert the male end of the flue, the smallest diameter pipe, into the flue outlet of the fireplace and press down until the snap locks engage. Continue the process, adding the chimney sections on top of each other until the chimney is at least six inches above the roof opening on all sides. As the chimney sections are installed, check each joint to make sure it is properly locked to the previous section. If additional strength of the outer pipe joints is desired, you may use two or three sheet metal screws placed through the area where the outer pipes overlap one another. To install these screws, drill a 1/8 inch diameter hole through the chimney sections, taking care to not penetrate the inner flue pipe. **WARNING: BE VERY CAREFUL WHEN DRILLING THE HOLES INTO THE OUTER PIPE. THE DRILL MUST NOT PENETRATE THE INNER STAINLESS STEEL PIPE.**

NOTE: If you intend to have a total fireplace installation of more than 30 feet, you must use chimney support model SCS at or below 30 feet to support the weight of additional chimney pipe. If it is impossible to nail the chimney support to the load bearing framing of the building

To install the chimney support, place the crimped end of the flue and outlet air duct portions into the last section of chimney pipe (see figure 17). Push down until the outside or inlet air duct of the chimney support overlaps and snap locks the chimney support into the chimney section.

Nail the support straps tightly to a building frame member or ceiling joist as shown by figure 17. You must use at least two 8 penny nails per strap.

CHIMNEY OFFSET INSTALLATION

Elbow Installation:

The following are important points that should be observed when installing elbows on the fireplace:

1. The support straps of all elbows not installed directly on top of the fireplace should be nailed securely to the surrounding structure. This allows the support straps to carry the weight of the chimney above the elbow and prevents this weight from breaking the elbow or chimney sections apart. (See figure 18.)
2. Elbows should not be used in any combination that will incline the chimney more than 30 degrees from vertical.

FIGURE 18 ALL FOUR SUPPORT STRAPS MUST BE NAILED ON TO FRAMING MEMBER AROUND THE ELBOW WITH A MINIMUM OF TWO (2) 8-PENNY NAILS PER STRAP

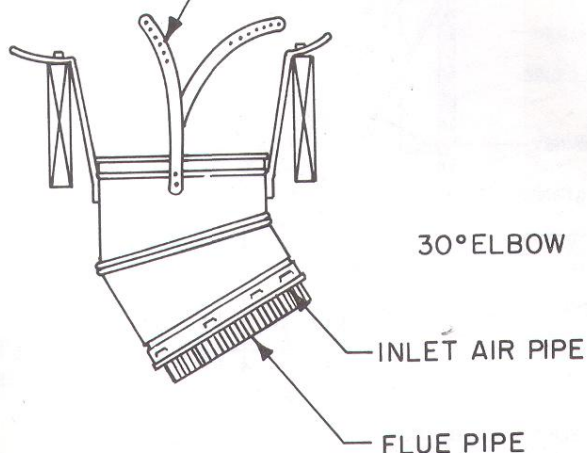

TABLE 2 SELECT DESIRED OFFSET AND READ ACROSS TABLE TO OBTAIN RISE, QUANTITY OF CHIMNEY SECTIONS & ELBOWS						
30° ELBOW						
Offset	Rise	1 Ft. Sections	1-1/2 Ft. Sections	3 Ft. Sections	4 Ft. Sections	Elbows Req'd.
4-1/2	17					1 PR.
9-3/8	25-5/16	1				1 PR.
12-3/8	30-1/2		1			1 PR.
17-3/4	39-13/16	1	1			1 PR.
20-3/4	45		2			1 PR.
23-1/8	49-1/8	2	1			1 PR.
26-3/4	55-3/8	1		1		1 PR.
32-3/4	65-13/16	1			1	1 PR.
35-3/4	71		1		1	1 PR.
38-3/4	76-3/16			2		1 PR.
41-1/8	80-5/16	1	1		1	1 PR.
44-3/4	86-9/16			1	1	1 PR.
47-1/8	90-11/16		1	2		1 PR.
50-3/4	97				2	1 PR.
56-1/8	106			3		1 PR.
59-1/8	111-1/2		1		2	1 PR.
68-1/8	127			1	2	1 PR.

* **RISE** is the number of inches in vertical height reached by the combinations shown.

** **OFFSET** is the number of inches which the centerline of the chimney is moved horizontally by the combinations shown.

FIGURE 19

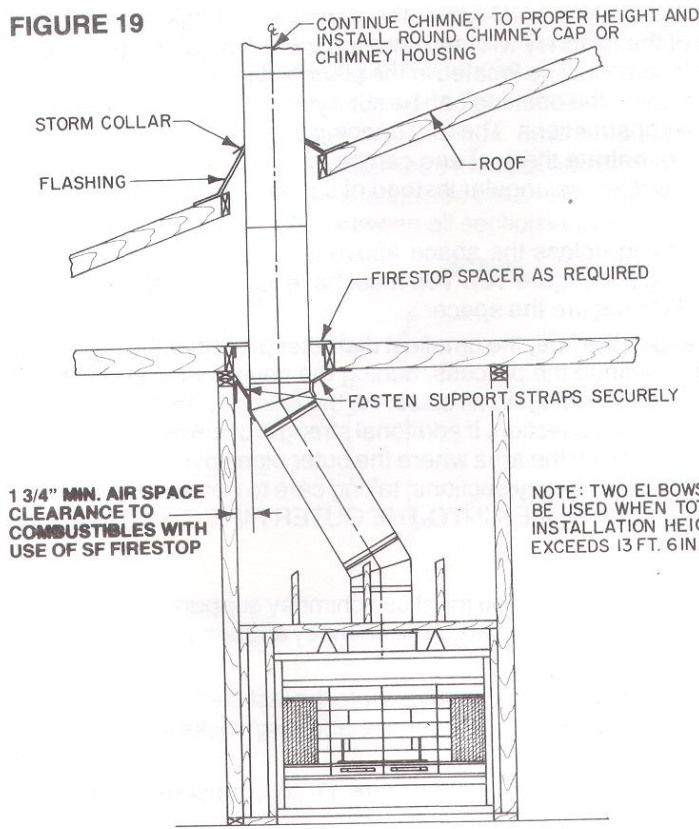

FIGURE 21

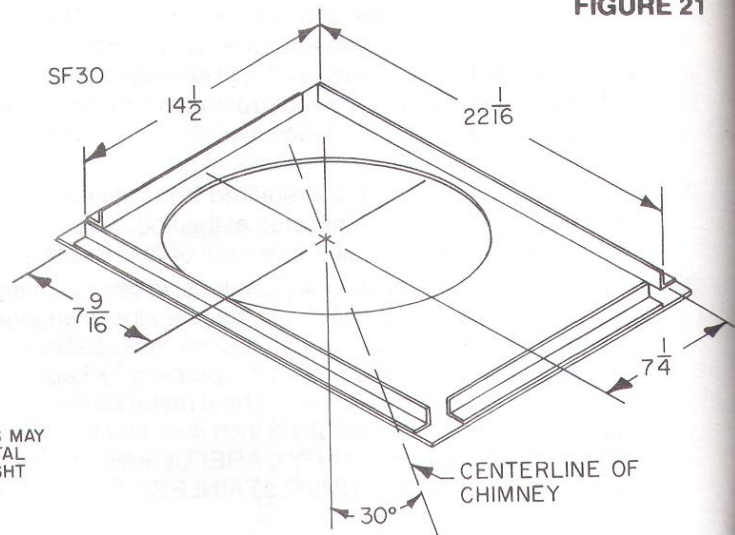

FIGURE 19A

TRIPLEWALL ELBOW INSTALLATION

NOTE

When installing a TRIPLEWALL elbow directly on top of the fireplace, bend the (4) tabs located on the fireplace inlet air collar bracket as shown below. These tabs may be bent sideways with your fingers or pliers easily, and when bent provides clearance for the outlet air duct of the elbow.

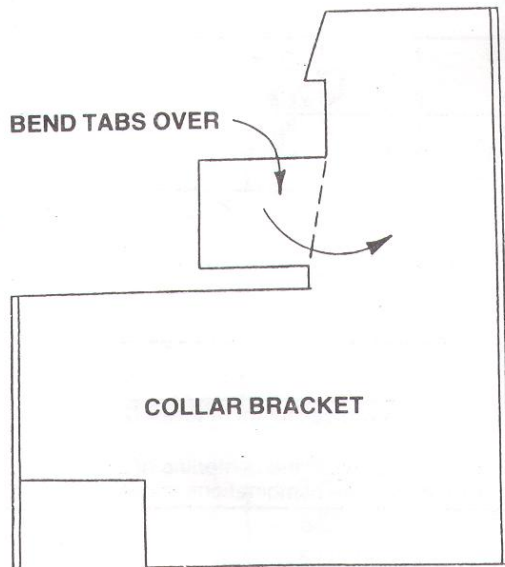
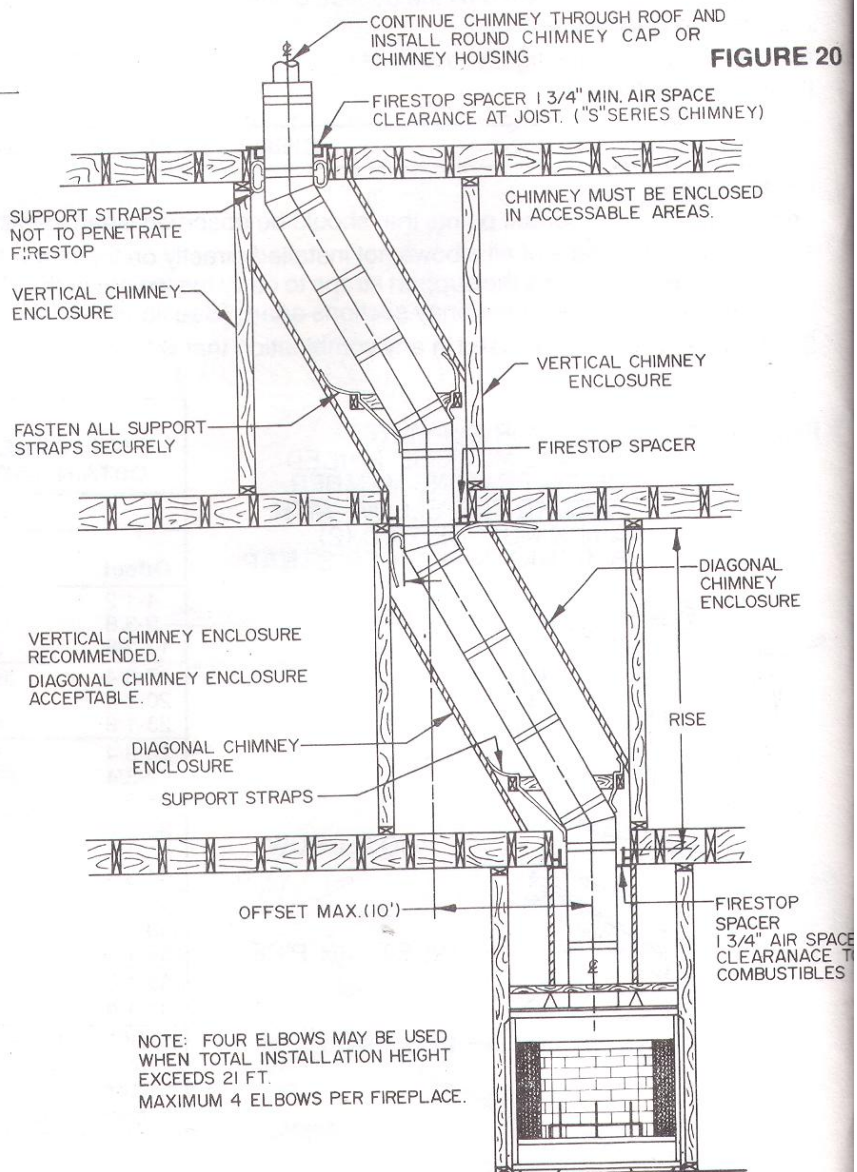

FIGURE 20



3. The limitations on the quantity of elbows per chimney are as follows:
If the total height of the fireplace and chimney is--
13'-6" or more--two elbows may be used in the chimney.
21'-0" or more--four elbows may be used in the chimney.
4. The inclined portions of chimneys that pass through living spaces likely to be used for storage should be enclosed to avoid contact with and possible damage to the chimney. The minimum air space of two inches between the chimney and enclosing materials must be maintained. Figures 19 and 20 illustrate some ways elbows may be used.
5. The length of the inclined portion of chimney between elbows must not exceed 6 feet when unsupported or 20 feet if the chimney is supported at six foot intervals with some means of support such as metal support straps.
6. When enclosing the elbows and inclined portions of the chimney, enclosing materials must be installed vertically so as to maintain the required two inch minimum air space clearance to the chimney at the extremities of the offset. It is recommended that enclosing materials not follow the inclined portions of the chimney. (Refer to figures 19 and 20).

Offset Installation Sequence:

1. Determine the location and amount of offset required, then select the combinations of chimney sections and elbows required from the OFFSET CHART, Table 2.
2. Install the first SE30 elbow by placing the crimped end into the mating part of the fireplace or chimney section. Push down until the outside or inlet air duct of the elbow overlaps and the snaps lock the elbow into the fireplace or chimney section.
3. Nail the support straps to the framing member with a minimum of two 8-penny nails per strap.
4. Install the sections of pipe between the elbows until the proper number of chimney sections have been installed.
5. Install the second elbow to return the run of the chimney to vertical.
6. Nail the support straps of the second elbow to a building frame member.
7. Continue installing the vertical portion of the chimney.

NOTE: If the inclined portion of the chimney passes through a floor ceiling a SF firestop spacer should be installed to provide the firestop and support required. Figure 21 provides the dimensions of the accessory. Be sure proper spacing is maintained between the chimney and combustibles.

CHIMNEY CAP INSTALLATION

Model SC Chimney Cap:

SPECIAL NOTE: The proper chimney height as previously explained is important to assure proper draft and safety. The chimney cap extends the flue outlet four inches above the top of the last section of chimney. This should be kept in mind when determining the proper height for the chimney. The chimney should not be extended more than 90 inches above the supporting roof structure without additional support. In the case of an "A" frame type construction or other steep pitch roofs that require more than 90 inches of chimney above the roof, a support should be attached to the chimney at the 90 inch level that is strong enough to support a wind load of 3-1/8 pounds for each inch the chimney extends above 90 inches. The flue outlet must be a minimum of three feet above the point where it penetrates the roof as shown by figure 14.

CAUTION: Be careful around electrical wires to avoid the electrical shock hazard of contacting the wires with the metal chimney components.

FIGURE 22

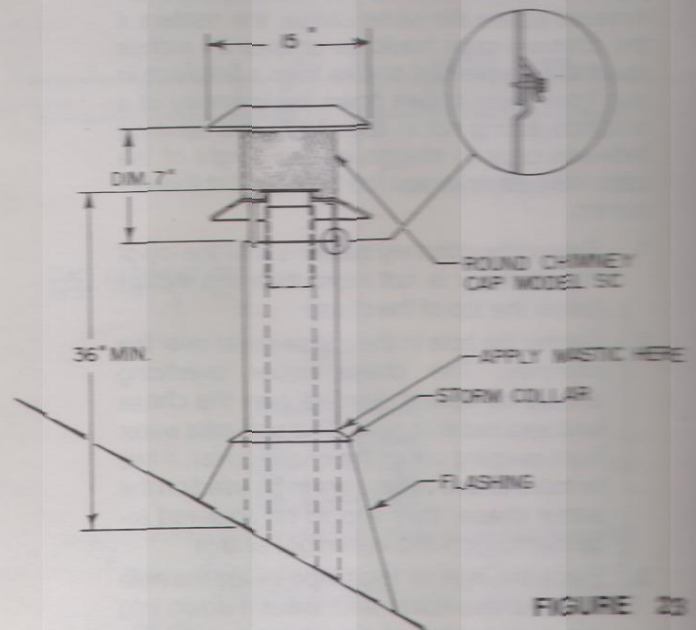
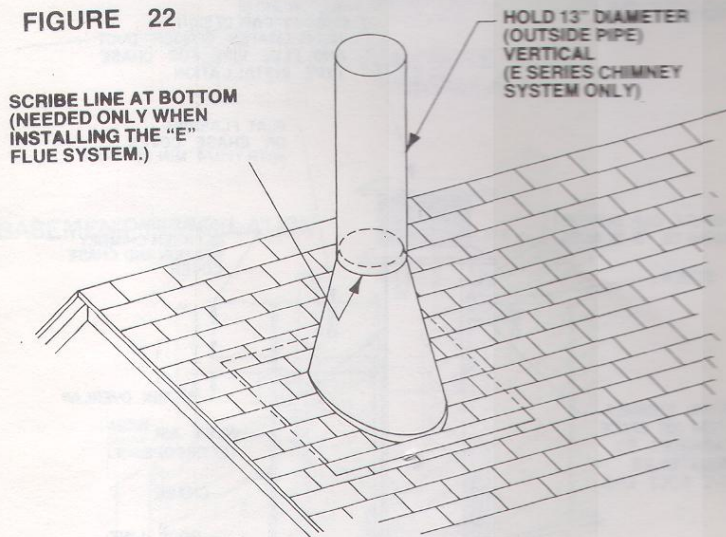

FIGURE 23

1. Extend the regular chimney sections until the top of the chimney is four inches below the total flue height desired. Do not snap the last section of inlet air duct or largest diameter pipe in place until step three is completed.
2. Remove the shingles from around the chimney so that the flashing may be installed, as shown by figure 22 with the upper part of the flashing under the shingles.
3. Set the flashing on the roof and scribe a line around the flashing as described by figure 22, then cut the top off the flashing by cutting 1/4 inch below the scribed line. This should increase the diameter of the flashing outlet sufficiently to allow the flashing to be placed over the chimney.
4. Snap the last section of inlet air duct in place and slide the flashing over the chimney. Adjust the chimney to assure that the proper minimum clearances are maintained.
5. Nail the flashing securely in place with eight nails. (See figure 23 for identification of the parts required for the installation.)
6. Seal the crack between the top of the flashing and the chimney with mastic. Leave some excess mastic at this area to be used in step eight.

NOTE: Use pliers and wear gloves when performing step seven to minimize the danger of cutting your hands on the edge of the storm collar.

7. Place the storm collar around the chimney and put the collar together like a belt in belt loops. Slide the end of the collar under the two loops on the other end with the loops facing up. Overlap the ends of the collar until it is tight against the chimney. Bend the free end of the collar back over the loops to hold the storm collar securely together. The excess end of the storm collar may be trimmed off.
8. Slide the storm collar down snugly against the flashing until the excess mastic left in step six is forced up into the crack between the storm collar and the chimney. This should make the joint between the flashing and the chimney watertight.
9. Install the chimney cap by placing the cap into matching parts of the last chimney section as shown by figure 23. Push down until the brackets on the bottom of the chimney cap sits on the chimney pipe. Then punch or drill 1/8 inch diameter holes in the inlet air duct (chimney pipe) where specified on the brackets and fasten it down with the No. 8 screws provided.
10. Check all the parts of the fireplace, chimney and chimney termination cap to assure that no parts have been damaged or bent during installation and that all parts have been installed properly.

NOTE: The metal used for the chimney and chimney cap has a rust protective coating but the cut edges of the parts are not protected. To prevent rusting and rust staining of nearby structures, exposed parts of the chimney and chimney cap should be detergent washed and painted with a galvanize primer paint.

MODEL SCL or SQL8 CHIMNEY CAP FOR CHASE INSTALLATION

The preinstalled chimney sections should be no more than ten inches below the top of the chase. The installation should be planned so that either a two foot or three foot chimney section will be used for the top section. This is necessary to insure complete engagement of the inlet air telescope and chimney cap into the top section.

CAUTION: Be careful around electrical wires to avoid the electrical shock hazard of contacting the wires with the metal chimney components.

NOTE: When two fireplace chimneys are terminated above the same chase, the centers of the chimney caps should be at least 24 inches apart to help prevent smoke from a fireplace in use from being drawn down the chimney of a fireplace that is not in use. Additional spacing between caps or staggering the height of the caps will further lessen the likelihood of this occurring.

1. Extend the chimney sections until the top of the chimney is not more than ten inches below the top of the chase.
2. Center the hole in the chase cover over the chimney. The chase cover overhang should be lanced, formed over the chase and secured with nails. This prevents water from seeping under the chase cover. If two or more chase covers are to be used on the same chase, they should be soldered together to form two watertight seams.
3. Place the inlet air telescope inside the hole in the chase cover and lower it down into the mating pipe of the chimney until the flange on the telescope section rests on the flange of the chase cover.

FIGURE 24

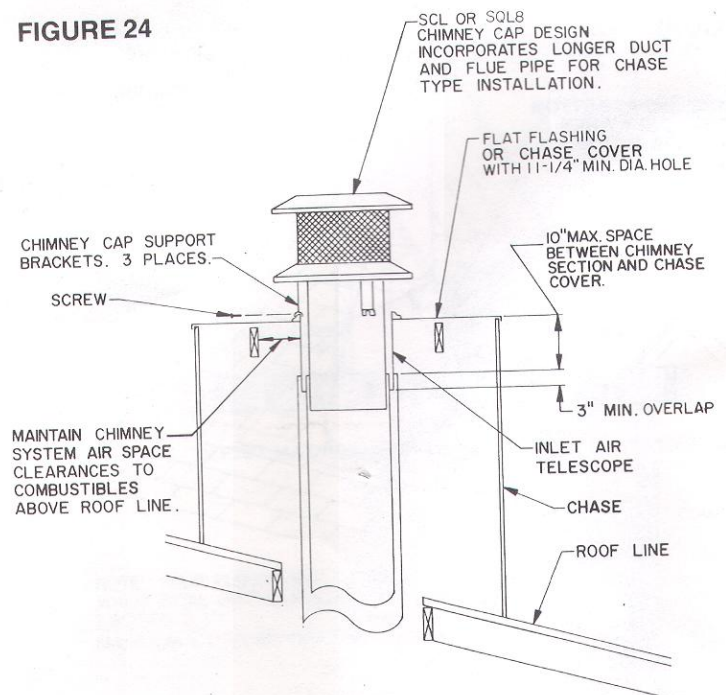

NOTE: All telescoping sections should extend a minimum of three inches inside the mating chimney pipes.

4. Install the SCL or SQL8 chimney cap by placing the cap into the matching duct telescope and flue telescope of the last chimney section as shown by figure 24. Lower the cap until the brackets on the bottom of the chimney cap rests on the raised flange of the flat flashing, punch or drill 1/8 inch diameter holes in the raised flange of the flat flashing, and fasten the cap to the flashing with the No. 8 screws provided.
5. Check all parts of the chimney and chimney cap to assure that no parts have been damaged or bent during installation and that all parts have been installed properly.

NOTE: The metal used for the chimney and chimney cap has a rust protective coating but the cut edges of the parts are not protected. To prevent rusting and rust staining of nearby structures, exposed parts of the chimney and chimney cap should be detergent washed and painted with a galvanize primer paint.

OUTSIDE COMBUSTION AIR PRECAUTIONS AND RECOMMENDATIONS

NOTE: The use of outside air for combustion is optional unless required by building codes. It is only necessary to supply outside combustion air to one side of the fireplace. Use the model AK4 combustion air kit.

FIGURE 25

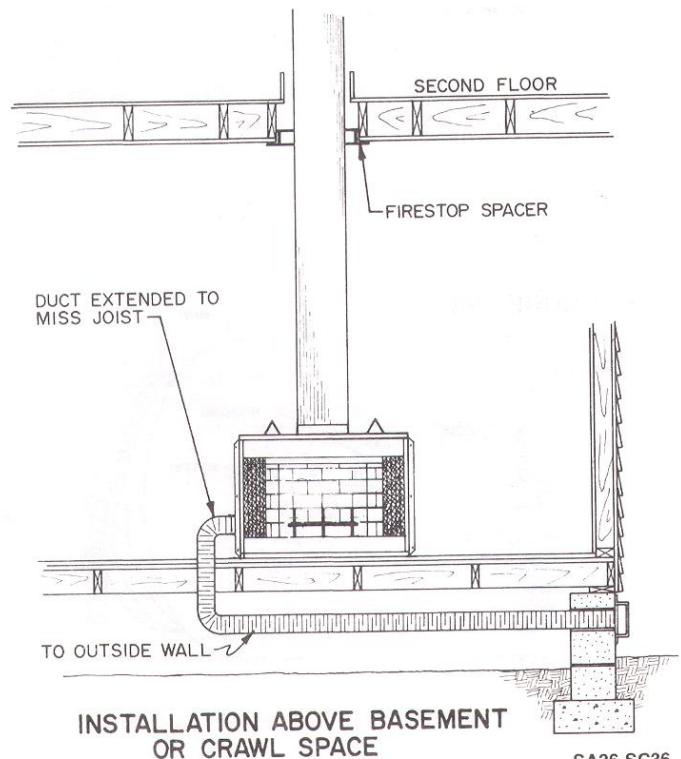
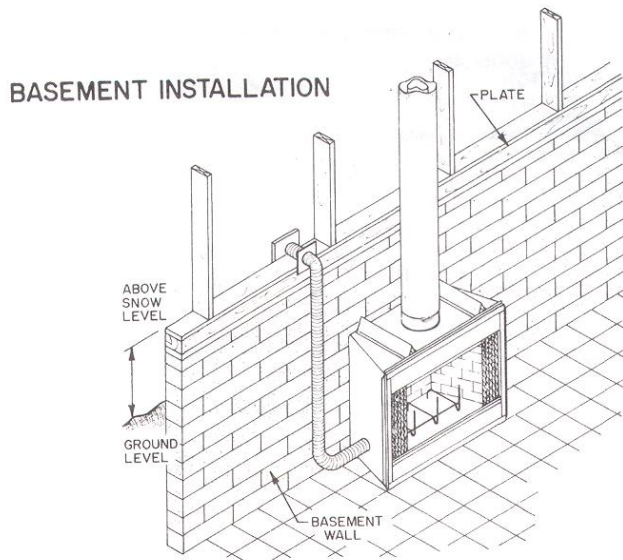
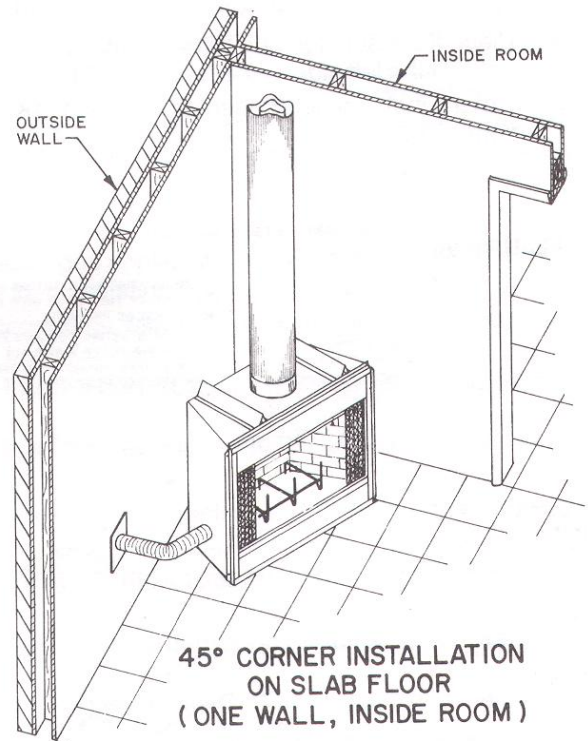
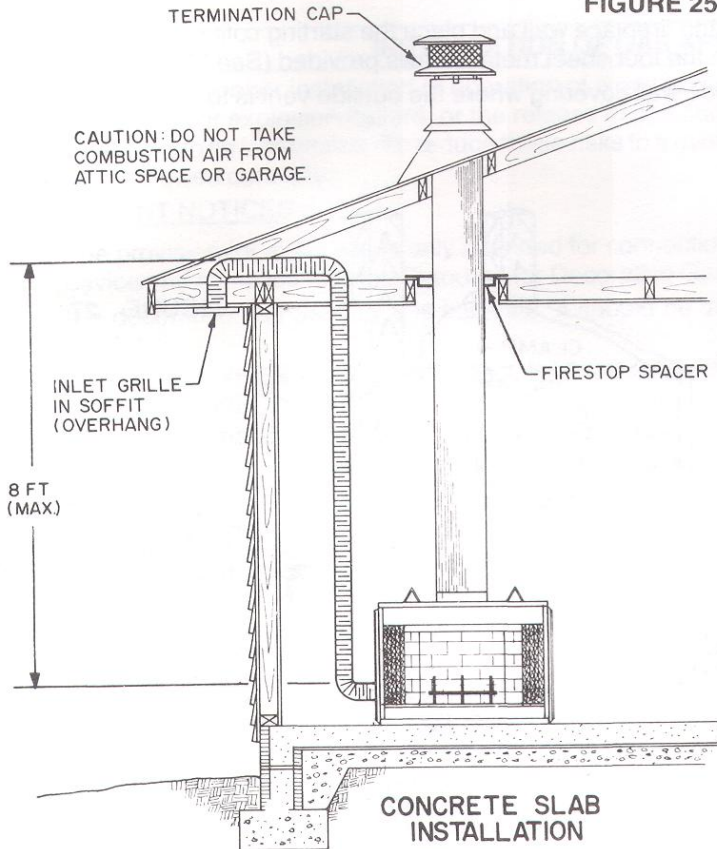

1. Extremely long runs and numerous turns in the duct leading from the fireplace to the combustion air assembly should be avoided. These conditions will increase the resistance to the free flow of air through the duct, thus lowering the efficiency of the fireplace. Refer to figure 25 for typical methods of installing the outside air for combustion assemblies.
2. The combustion air assembly should be located at an exterior location which is not likely to be accidentally blocked in any manner. The assembly should be located above the snow line to prevent blockage by snow accumulation.
3. The combustion air inlet assembly should never be mounted in a garage or storage area where combustible fumes such as gasoline might be drawn into the fireplace.
4. Combustion air can be drawn from the crawl space under a house when an adequate supply of air is provided by open ventilation.
5. Do not take combustion air from attic space or garage space.

COMBUSTION AIR ASSEMBLY INSTALLATION PROCEDURE

Model AK-4 Combustion Air Assembly:

1. Remove the cover plate from the 4 inch outlet opening location on the left outside of the fireplace. Do not remove the cover if the outside air will not be connected.
2. Place the insulation ring between the AK4 starting collar and fireplace wall and place the starting collar (4 inch) into the hole on the left side of the fireplace. Fasten it in place with the four sheet metal screws provided (See Figure 26).
3. Cut a 5 inch diameter opening for model AK-4 in the outside wall covering where the outside vent is to be located. (See figure 27.)

FIGURE 26 SECURING OUTSIDE AIR STARTING COLLAR TO FIREPLACE

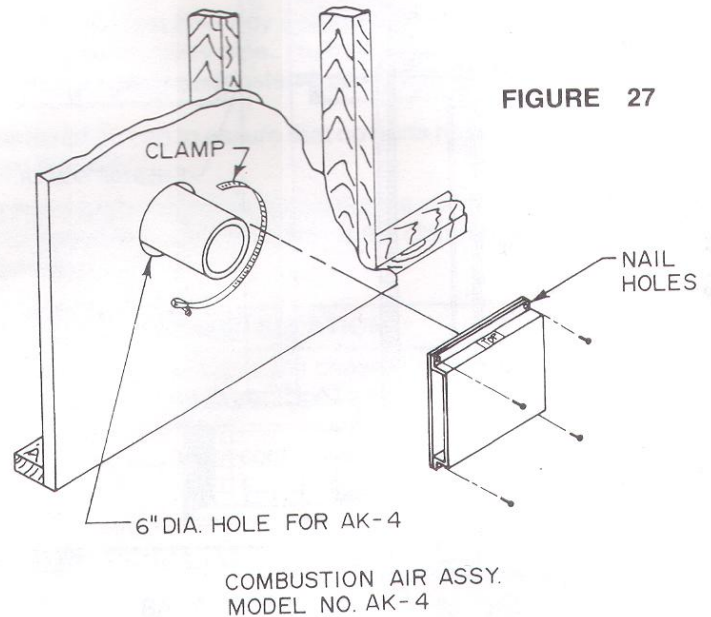
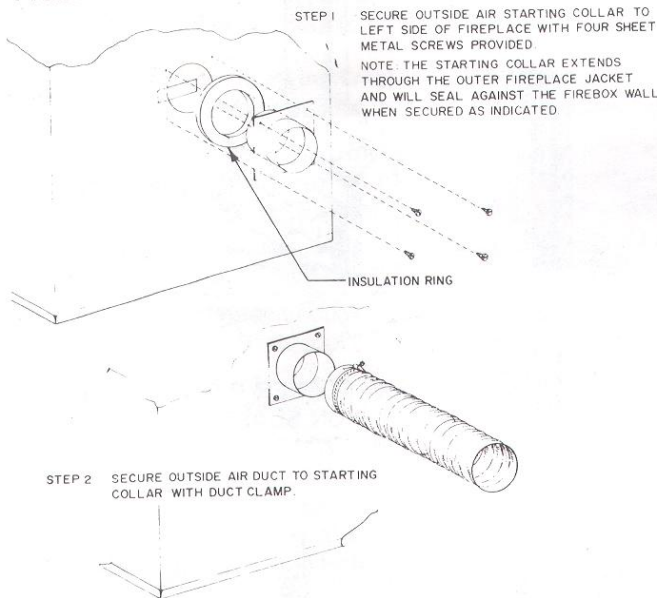
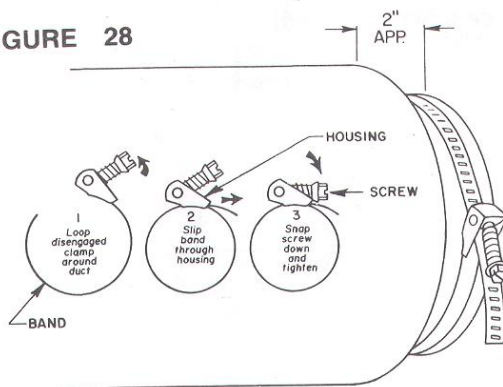

FIGURE 27

FIGURE 28



INSTALLATION OF THE MODEL 403 DUCT CONNECTOR

1. Push the insulation back approximately 2" from the end of each duct.
2. Slip each duct over the duct connector until an equal length of the connector extends into each duct.
3. Place a duct clamp over the end of each duct and tighten it down snugly.
4. Push the insulation back into place and over the duct clamp.

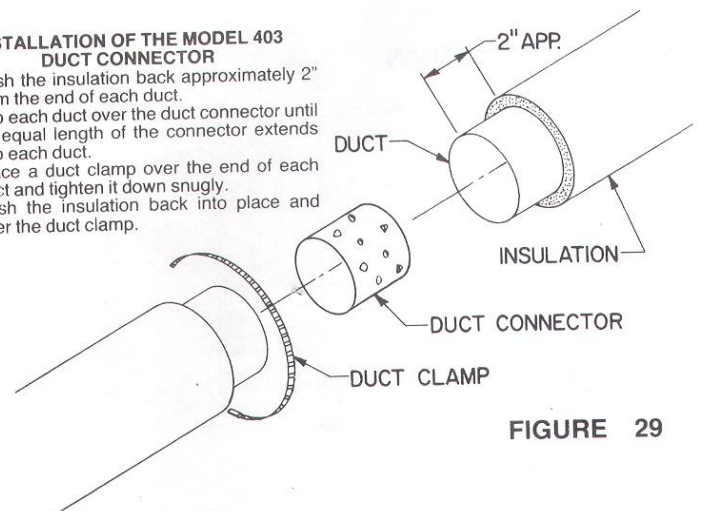

FIGURE 29

4. Select and cut a piece of duct of sufficient length to attach to the fireplace and protrude at least three inches beyond the face of the wall to which the AK-4 inlet air vent will be attached. The duct may be cut with a standard pocket knife. (Use Martin FP-4-U duct for maximum efficiency and safety.) Do not use a combustible duct. Always use UL Listed Class 0 or 1 duct material.
 5. If the duct is the insulated type, push the insulation back from one end of the duct approximately two inches. (See figure 28.)
 6. Slip the exposed end of the duct over the starting collar on the fireplace.
 7. Place the duct clamp around the exposed end of the aluminum duct.
 8. Slip the band through the housing, then pull the band tight around the duct.
 9. Snap the band locking screw down and tighten it with a screwdriver or nutdriver. (See figure 28.)
 10. Nail or screw the combustion air assembly to the surface of the wall.
- NOTE: If the wall covering is brick or stone, use appropriate masonry fasteners. Mount the combustion air assembly with "TOP" upward to prevent rain from entering the assembly. Be sure the 6 inch diameter opening around the air duct is sealed with insulation material to prevent cold air from entering through the wall. If it is necessary to splice the duct, a model 403 duct connector should be installed as described by figure 29.

INSTALLATION OF GAS APPLIANCE IN THE FIREPLACE

WARNING: Improper installation or operation of a gas appliance in this fireplace can allow unburned gas to leak out which will cause a fire or explosion hazard, or the release of poisonous carbon monoxide into the dwelling which can cause serious injury or death to its inhabitants. To reduce these risks to a minimum, the following important notices and instructions should be read and followed carefully:

IMPORTANT NOTICES

1. The provision for a gas line is only intended for connection to a decorative gas appliance which has an automatic shutoff device and complies with the Standard for Decorative Gas Appliances for Installation in Vented Fireplaces, ANSI Z21.60. If a decorative gas appliance is installed, it should be installed in accordance with the National Fuel Gas Code, ANSI Z223.1.

CAUTION: "WHEN USING THE DECORATIVE GAS APPLIANCE, THE FIREPLACE DAMPER SHOULD BE SET IN THE FULLY OPEN POSITION."

2. An approved gas shut off valve must be located outside the fireplace in an area accessible to the users of the fireplace.
3. All gas piping and fittings must be either steel or malleable iron.
4. Some code authorities prohibit or place restrictions on the use of gas appliances in fireplaces. Check with local code authorities before proceeding with the installation.
5. The gas appliance and all connecting gas piping should only be installed by a licensed gas appliance installer. See figure 13 for the gas line opening dimensions on the fireplace.
6. The installer should advise the persons who will use the appliance to set the fireplace damper in the full open position when the appliance is in use.

The following instructions only apply to passing the gas line through the fireplace wall. Follow the instructions provided by the appliance to the gas line, testing, and adjusting it.

1. Locate the recessed area in the side refractory panel as shown by figure 30.
2. Tap out a round hole in the brick liner with a hammer by tapping lightly on the recessed area.
3. Remove the two screws that hold the cover plates on the jacket wrap and discard the cover plate.
4. Use a screwdriver or similar tool to push the loose insulation out of the tube between the firebox and the outer jacket of the fireplace.
5. Install the gas pipe through the tube between the firebox and jacket.
6. Attach the gas appliance to the gas pipe according to the appliance makers instructions.

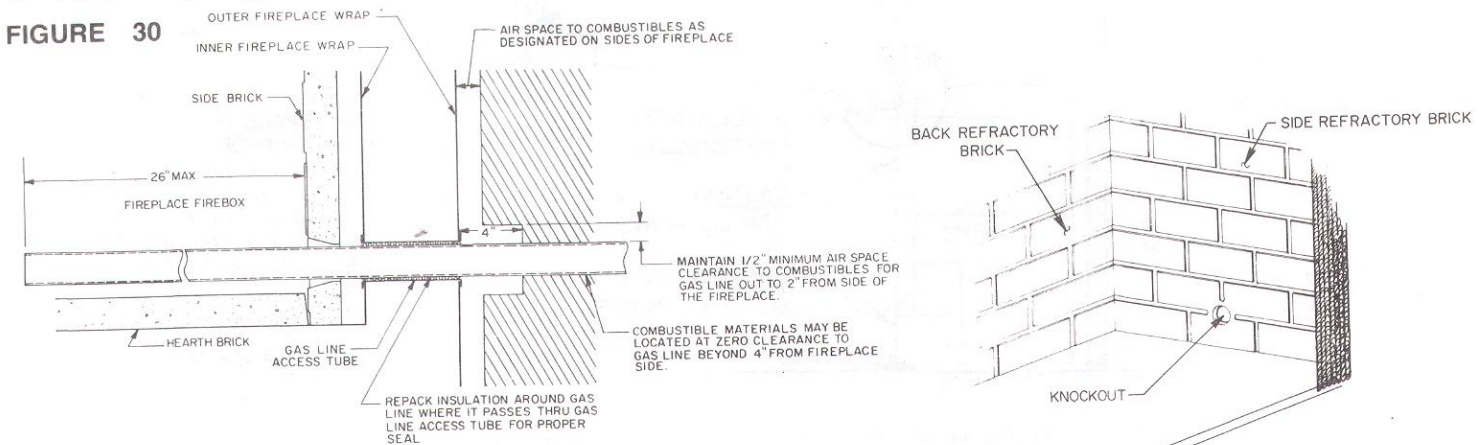

CAUTION: WHEN USING A GAS APPLIANCE, THE FIREPLACE DAMPER MUST BE SET IN THE FULLY OPEN POSITION

7. Pack the insulation removed in step 4 around the pipe to prevent air flowing through the tube either into or out of the firebox.
8. Be sure the gas is turned off at the appliance, then turn the gas on at the cut off valve and test the gas line connections for leaks with a soapy water solution or a liquid leak detector. **DO NOT USE A MATCH OR OTHER FLAME SOURCE TO CHECK FOR GAS LEAKS.** If a gas leak is detected, turn the gas off immediately and fix the leak.
9. Proceed with testing the appliance for leaks and adjusting it as required by the appliance manufacturers instructions.

APPLYING DECORATIVE TRIM TO THE FIREPLACE

DO NOT ALLOW THE TRIM MATERIALS TO EXTEND CLOSER THAN 3/8 INCH TO THE VERTICAL EDGES OF THE FIREBOX OPENING IF YOU PLAN TO EQUIP THE FIREPLACE WITH GLASS DOORS.

The face of your fireplace may be left exposed or trimmed with any noncombustible material such as brick, stone or marble. If a trim is installed, be sure it is fastened snugly to the face of the fireplace. A crack between the trim material and the face of the fireplace could pose a fire hazard and impair the proper operation of the fireplace. (See figure 32.) Blocking the fireplace with framing and attaching the base to the supporting floor will further reduce the possibility of such a crack developing.

Wall ties should be fastened to the face of the fireplace with sheet metal screws and placed in the mortar joints of masonry trim. Combustible materials must not be installed below the top spacers of the fireplace or overlap the sides of the fireplace face. Seal the face of the fireplace to the surrounding wall with non-combustible caulk or trim materials to prevent cold air leakage around the fireplace.

The trim should not block or restrict in any way the flow of air into the air inlet or warm air outlet louvers in the face of the fireplace. (See figure 31A and 32.)

Be sure to provide the required floor protection as described in a preceding section of this manual.

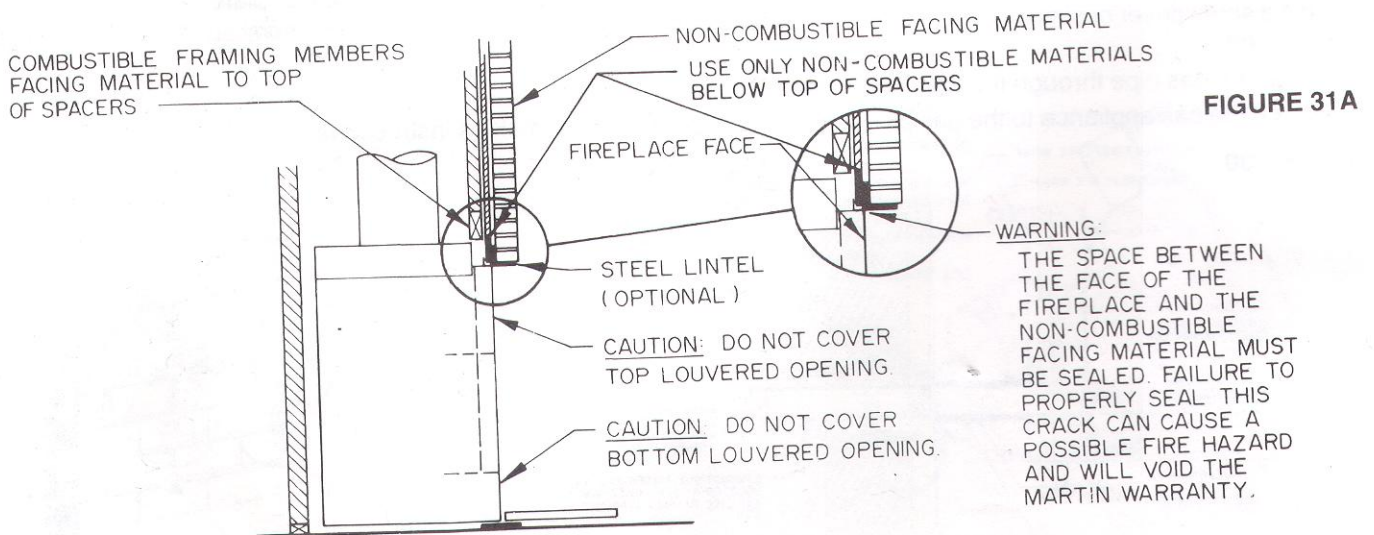
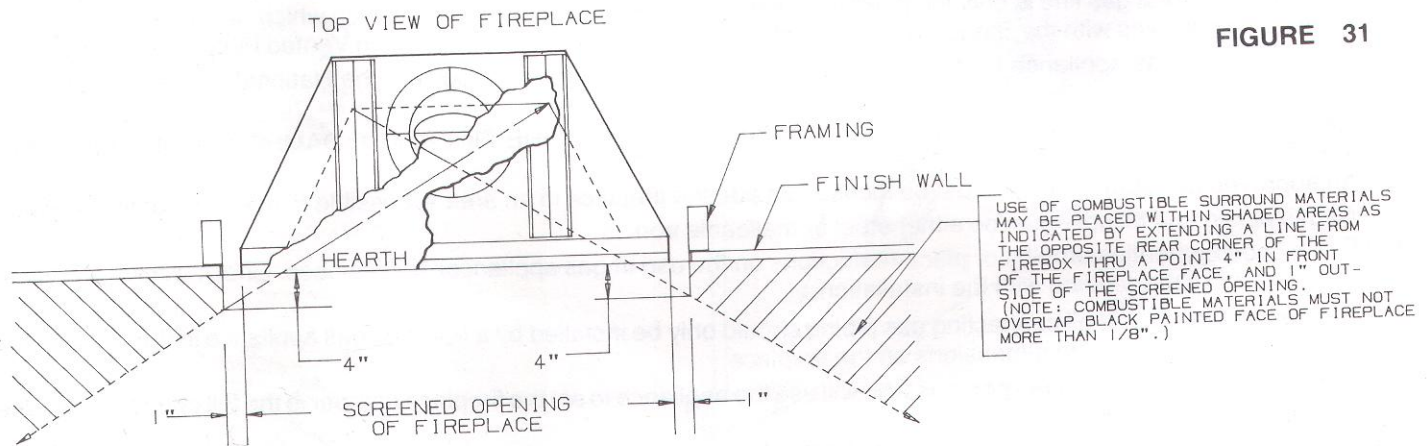

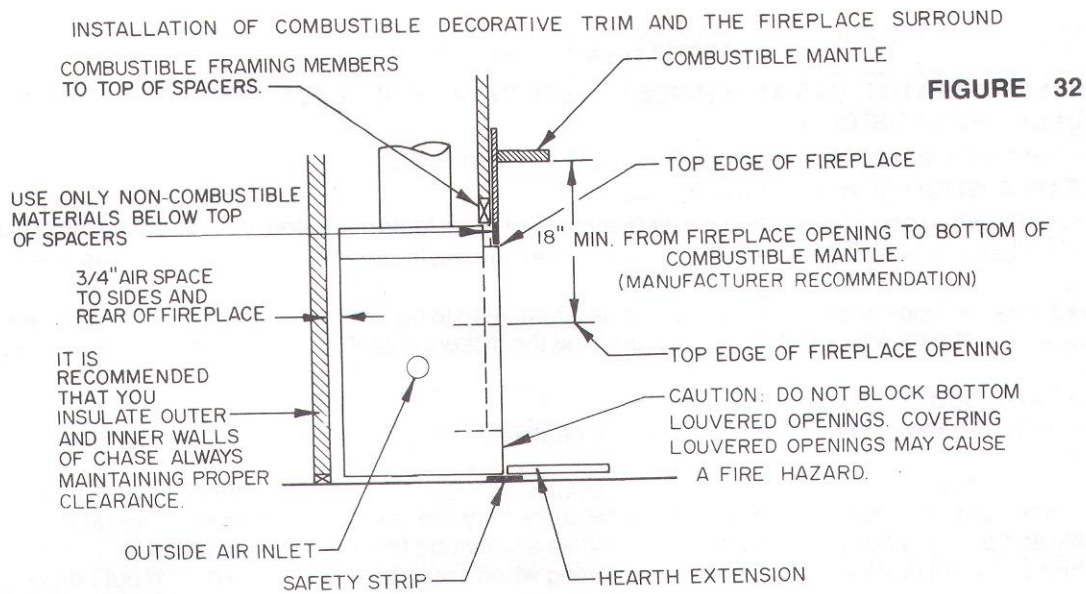

GLASS DOOR INSTALLATION

This fireplace has been tested and listed for use with Martin model WB36 glass doors. These glass doors are sold as optional equipment. For installation of the Model WB36 glass doors, see the instructions provided with the doors.

FAN ACCESSORY

The model SC36 fireplace may be equipped with a Martin accessory fan Model FA2. If the fireplace is to be equipped with this accessory at anytime, the JB1 junction box assembly must be installed on the fireplace as shown by Figures 33 and 34 during the installation of the fireplace. Unless the JB1 junction box is installed at this time, wall finishing materials must be removed to gain access to the side of the fireplace to install the JB1 junction box at a later date. Complete Installation Operation Instructions for the FA2 Fan are included in the package with this accessory.

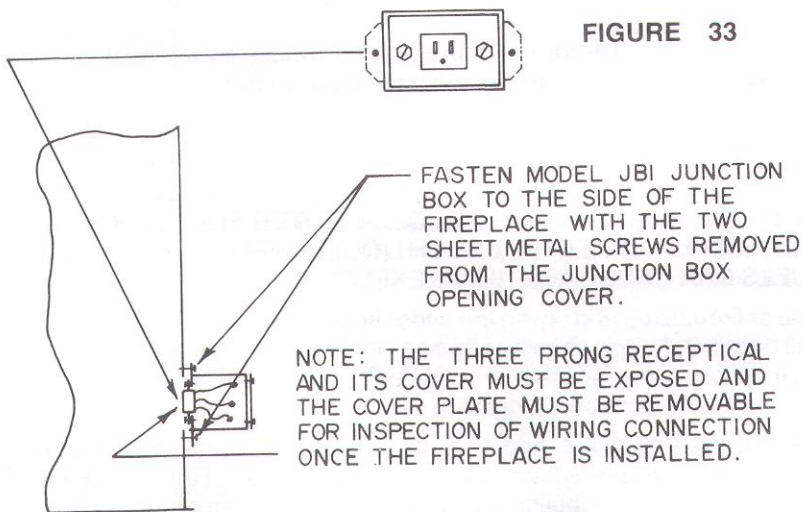

MODEL JB1 JUNCTION BOX INSTALLATION

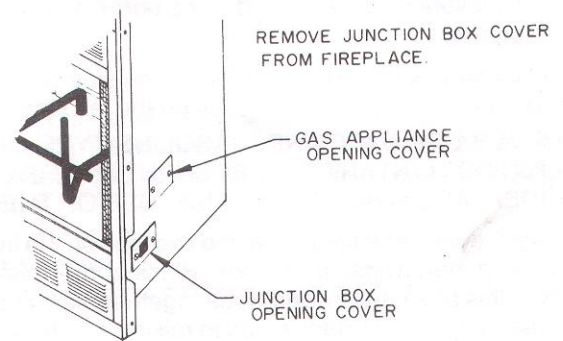

FA2 WIRING DIAGRAM

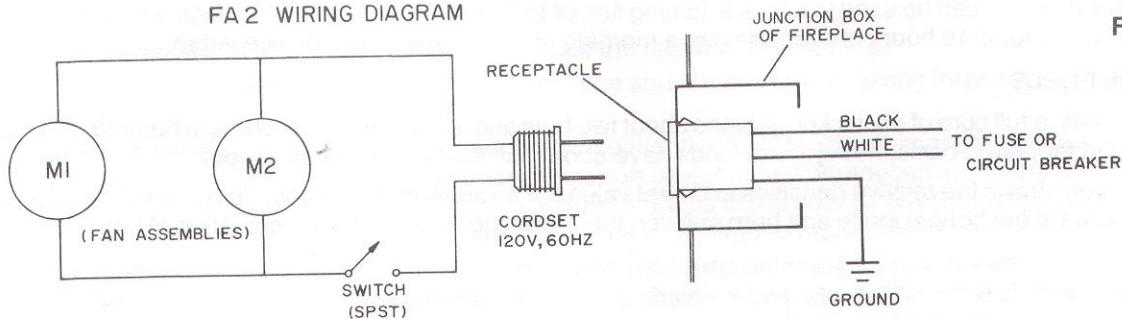

NOTE: THE JB1 JUNCTION BOX SHOULD BE INSTALLED AND THE RECEPTACLE WIRED TO THE ELECTRICAL SYSTEM OF THE STRUCTURE AT THE TIME OF INSTALLATION OF THE FIREPLACE IF THE FA2 FAN ASSEMBLY IS TO BE USED.

OPERATION OF THE FIREPLACE

WARNING: IF A DECORATIVE GAS APPLIANCE IS USED IN THE FIREPLACE THE FIREPLACE DAMPER MUST BE SET IN THE FULLY OPEN POSITION.

(See additional operation information in section titled "How the Fireplace Operates".)

ADVANTAGES OF A WOOD BURNING FIREPLACE

In times of emergency, when power lines are down or deliveries of fossil fuels disrupted, your fireplace can be used for cooking. Wood has a low ash content. And the little ash that remains after burning is useful in home gardening as a fertilizer and soil conditioner.

These are the practical, ecological advantages of wood as a fuel. Also to be considered is the aesthetic appeal. Most of us consider a wood fire with nostalgia. We enjoy the aroma, and find the flickering light of a cozy hearth conducive to a happy remembrance of things past.

WHICH WOODS ARE BEST?

Each wood species offers something different in aroma or heat value, and you should consider your needs and desires before building your fire.

Softwoods, like pine, spruce, and fir are easy to ignite because they are resinous. However, a fire built entirely of softwoods burns out quickly and requires frequent replenishment. While a softwood fire is not too desirable for a long evening, it's fine in the morning when you want quick warmth, or for late evening when you want a fire that will burn out before you go to bed.

On occasion when a longer fire is desired, it's best to combine softwoods with the heavier hardwoods such as ash, beech, birch, maple, oak, and hickory. These hardwood species burn less rapidly, with shorter flames, and produce steady, glowing coals.

For the most pleasing aroma, you'll want to burn the wood of fruit trees such as apple and cherry, or nut trees such as beech, hickory, and pecan. Such wood is generally more expensive, but a little combined with other wood, goes a long way. Start your fire with a mixture of softwood and hardwood; then add some fruit or nut wood for nostalgic wood aroma.

Since most woods will not burn well when freshly cut, the wood you purchase should be reasonably dry. The sizes you buy are dictated by the size of your fireplace. Purchase logs that will fit when laid across your grate, and ask that the larger, heavier logs be split. Kindling should be short, easily-split lengths of softwood, lumber yard or mill scraps, or twigs and branches gathered from your yard.

HOW TO BUILD A BETTER FIRE

The first three fires should be of moderate size to allow the fireplace to adjust and the bricks to cure before being subjected to larger fires.

First, make sure your room is well ventilated, your damper open, and the flue is unobstructed. Then make sure your wood is dry and seasoned. Unseasoned wood burns poorly and coupled with poor ventilation or an obstructed chimney, leads to smoking problems.

If your fireplace is equipped with an outside combustion air assembly open the combustion air inlet by pushing upward on the lever located above the firebrick on the left side of the firebox.

NEVER USE GASOLINE, GASOLINE-TYPE LANTERN FUEL, KEROSENE, CHARCOAL LIGHTER FLUID, OR SIMILAR LIQUIDS TO START OR "FRESHEN UP" A FIRE IN THIS FIREPLACE. KEEP ALL SUCH LIQUIDS WELL AWAY FROM THE FIREPLACE WHILE IT IS IN USE. USE OF THESE FUELS CAN CAUSE A SERIOUS EXPLOSION.

Begin laying your fire by placing two logs on the iron grate or firebasket, and laying the tinder between them. Tinder may be dry scrap paper, twigs, or dry bark. Place above this a small handful of twigs or split softwood kindling. Then place more dry logs over this base. Keep logs close together, since narrow air spaces between them promote better drafts, and heat reflected between adjacent surfaces aids in raising and maintaining combustion temperatures.

You'll need a minimum of three logs, and preferably four, to make a good fire. Add kindling and new logs as needed to rekindle a dying fire. New logs should be added at the rear grate after raking the coals toward the front. **DO NOT OVERFIRE THE FIREPLACE.** Overfire conditions may be created by large amounts of kindling, building scraps, or other improper fuels.

Ashes, important because they form a bed for glowing coals, should only be left to accumulate within an inch or two of the bottom of the grate. Excess ashes can be used to check a flaming fire; or to "bank" your fire, cover the logs with ashes. A "banked" fire will hold glowing coals for 8-10 hours, thereby saving a morning fire for evening use, or vice versa.

WOOD VS. FOSSIL FUELS

Compared to fossil fuels, a full cord of dry hickory weighs about two tons and is approximately equal in heating value to a ton of hard coal. On a pound for pound basis, heavy hardwoods have about half the heating value of coal.

The following tabulation shows the relative densities and heat values of a variety of dry woods. Those toward the top of the list burn longer. Those toward the bottom ignite and burn quicker; therefore, the best fire is a combination of both light and heavy woods.

SPECIES	DENSITY	HEAT VALUE	SPECIES	DENSITY	HEAT VALUE
Dogwood	.70-.79	100-107	Ash	.57-.61	81-82
Hickory	.70-.74	100	Southern Pine	.51-.60	73-81
Oak	.60-.73	86-99	Elm	.50-.59	71-80
Black Locust	.69-.70	95-98	Cherry	.50-.52	70
Beech	.64-.66	89-91	Douglas Fir	.45-.51	64-69
Hard Maple	.58-.65	83-88	Spruce	.41-.44	59
Birch	.55-.64	79-86	Redwood	.33-.40	47-54
Apple	.58-.62	83-84	White Pine	.35-.37	50

A FEW WORDS OF CAUTION

Beware of burning certain materials in your fireplace. Among these are plastics, poison ivy twigs and stems, and chemically treated woods such as discarded poles and railroad ties. These not only create air pollution, but can induce extreme irritation for some individuals.

Use hemlock, spruce, juniper, and other resinous woods with caution. They contain moisture pockets which, upon heating, "pop" with considerable vigor.

Always use a firescreen. And always "bank" a fire, or, at least, push all unburned fuel to the rear of the grate before leaving a fire unattended. Do not use this fireplace as an incinerator.

Because the termination of the chimney above the roof is exposed to wind and cold and the pressure changes these and other environmental conditions may cause, a sufficient chimney draft may be hard to establish at times. At other times the draft may be sufficiently disrupted to cause smoke to spill from the fireplace opening. If problems with chimney draft occur, help start a chimney draft before you build a fire by holding a piece of burning paper near the flue opening at the top of the firebox to preheat the chimney. If smoke spills from the fireplace opening after the fire is burning, open a window on the up wind side of the house that is far enough away from the fireplace that the wind will not blow across the fireplace opening, push the burning wood as near the back of the fireplace as possible, and if the fireplace is equipped with glass doors, close them.

DO NOT LEAVE CHILDREN OR PHYSICALLY OR MENTALLY HANDICAPPED, OR SENILE PERSONS ALONE WITH A BURNING FIREPLACE.

FUEL STORAGE

Wood can be dried sufficiently for burning within a few weeks if protected from rain in a low humidity area. It is far better to cut wood and allow it to dry for a year. In all cases, the wood should be stacked so that both ends of the sticks are exposed to the air and protected from rain. The drier the wood, the more usable heat produced by the fire and the less likely rapid accumulation of soot and creosote within the chimney is to occur. See the section of this manual concerning chimney maintenance for information concerning the hazards of soot and creosote accumulation. Small quantities of wood required for fire tending must be kept at least 30 inches from the fireplace.

DISPOSAL OF ASHES

Ashes should be placed in a metal container with a tight fitting lid. The closed container of ashes should be placed on a non-combustible floor or on the ground well away from all combustible materials pending final disposal. If the ashes are disposed of by burial in soil or otherwise locally dispersed, they should be retained in the closed container until all cinders have thoroughly cooled. Ashes should never be placed in a container with combustible materials.

FIREPLACE AND CHIMNEY MAINTENANCE

CHIMNEY MAINTENANCE:

CREOSOTE-Formation and Need for Removal

When wood is burned slowly, it produces tar and other organic vapors, which combine with expelled moisture to form creosote. The creosote vapors condense in the relatively cool chimney flue of a slow-burning fire. As a result, creosote residue accumulates on the flue lining. When ignited this creosote makes an extremely hot fire.

The chimney should be inspected at least twice a year during the heating season to determine if a creosote buildup has occurred.

If creosote has accumulated it should be removed to reduce the risk of a chimney fire.

The chimney cap can be removed for inspection, maintenance and cleaning by removing three screws from the support legs and lifting upward.

When the fireplace is first placed in use, inspect the chimney frequently and clean the chimney any time an accumulation is observed on the flue walls. The frequency of these inspections can be increased or reduced appropriately after a pattern of accumulation has been established. Please note, however, that changes in the outside environmental conditions such as temperature and humidity or changes in the operation of the fireplace can lead to rapid buildup of soot and/or creosote.

To clean the chimney, obtain the services of a qualified and reputable chimney sweep, or remove the accumulation with brushes on wooden or fiberglass poles. Do not use metal pipes, chains, wires, etc., to clean the chimney because such items can scratch the surface of the stainless steel flue which can shorten the life of the flue and provide a rough surface for soot particles to attach to.

Be sure to cover nearby furnishings and arrange some method of catching soot and creosote particles that may fall during the chimney cleaning process. If glass doors are installed on the fireplace, they should be closed. Extra caution must be used to avoid damage to the flue damper during the cleaning process.

In addition to checking and cleaning the chimney on a regular basis, be sure to inspect the chimney before starting a fire at the beginning of each heating season. Make sure the chimney is clear from any accumulation of soot, creosote or any other debris, and that all joints are intact.

Martin Industries does not recommend chemical cleaners because some may contain elements that corrode the metal parts of the chimney or fireplace.

FIREPLACE MAINTENANCE:

At the end of each heating season or when the fireplace will not be in use for an extended time, the ashes should be removed and the hearth area should be swept as clean as is practical. The slow absorption of moisture into the ashes over a long period of time could cause a condition which would be corrosive to the metal fireplace parts.

At the beginning of each heating season, always operate the flue damper and make sure it has not become stuck from soot, creosote, etc., during the period of inactivity.

Keep the lower and upper grille panels clean and free from dirt and lint accumulation at all times to get the maximum efficiency from your fireplace.

As you use the fireplace, expansion and contraction will cause minor cracking of the hearth, back, and side refractory materials. This is normal and unavoidable. If the cracks become large enough or parts dislodge and the metal behind the refractory is exposed, the refractory panels should be replaced with new panels that can be obtained from your Martin fireplace dealer.

GLASS DOOR MAINTENANCE

For glass door maintenance, see the instructions provided with the glass doors.

ORDERING PARTS:

Replacement parts for your fireplace can be obtained from your Martin dealer. Should you need additional information beyond what your dealer can furnish, contact Martin Industries, Inc., P.O. Box 128, Florence, AL 35631.

When ordering parts, specify:

1. Fireplace model number;
2. Component model number (if known);
3. Part number and key number;
4. Part name; and
5. Quantity.

Figures 35 and 36 should be used for reference in ordering parts.

KEY NO.	PART NAME	PART NUMBER	QTY. Per Ill.
1	Upper Panel Ptd. Assy.	020375	1
2	Hearth Ledge Ptd. Assy.	032075	1
3	Weldment Grate Assy.	031899	1
4	Hearth Refractory Assy.	031873	1
5	Firebrick Side Assy.	031872	2
6	Firebrick Back Assy.	031871	1
7	Firescreen Panels	033942	2
8	Weldment Air Door Rod	031867	1
9	Lower Panel Ptd. Assy.	033940	1

SA36 MODEL FIREPLACE (See Figure 35)

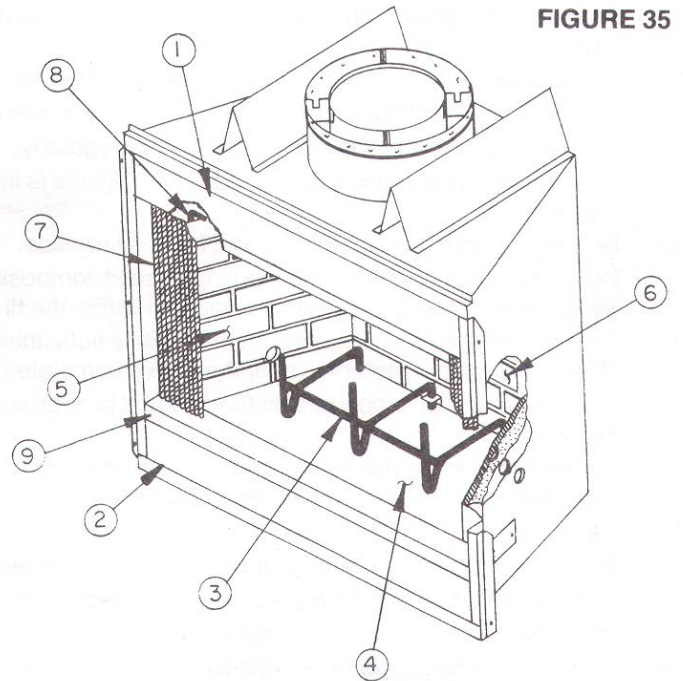

FIGURE 35

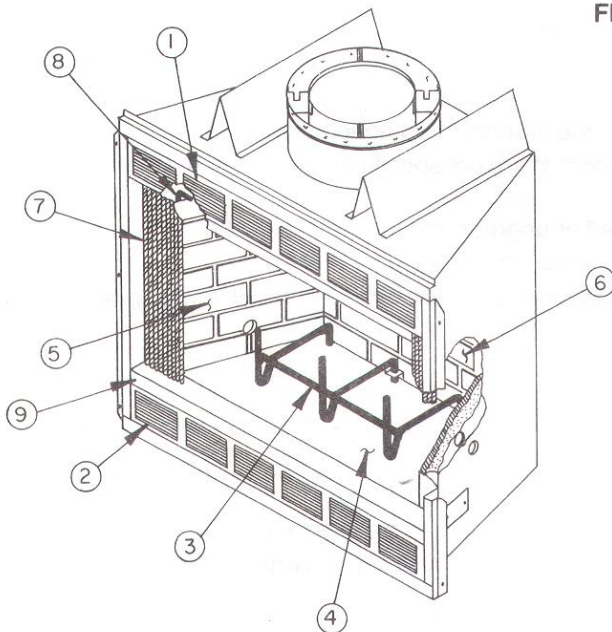

FIGURE 36

KEY NO.	PART NAME	PART NUMBER	QTY. Per Ill.
1	Upper Grille Panel Ptd.*	032076	1
2	Lower Grille Panel Ptd.*	020362	1
3	Weldment Grate Assy.	031899	1
4	Hearth Refractory Assy.	031873	1
5	Firebrick Side Assy.	031872	2
6	Firebrick Back Assy.	031871	1
7	Firescreen Panels	033942	2
8	Weldment Air Door Rod	031867	1
9	Ledge Hearth Ptd. Assy.	032075	1

SC36 MODEL FIREPLACE (See Figure 36)

CHECKLIST OF DO'S AND DON'TS

DO'S

1. Do check with local building officials to be sure the installation of the fireplace complies with all building codes and requirements and obtain required building permits.
2. Do plan your installation with safety as your primary consideration.
3. Do use only the prescribed materials and parts for the installation of the fireplace.
4. Do insulate the exterior walls surrounding the fireplace to prevent excessive heat loss from the fireplace.
5. Do trim the face of the fireplace only with noncombustible materials.
6. Do attach the noncombustible face trim materials firmly to the face of the fireplace.
7. Do block in or fasten the fireplace to prevent the possibility of the fireplace shifting out of position.
8. Do connect the air circulation blower to a properly grounded and fused electrical circuit.
9. Do enclose the chimney where it passes through living spaces or spaces accessible for storage purposes to prevent contact with the possible damage to the chimney.
10. Do install firestop spacers at each ceiling level when the chimney is installed in a multistory building.
11. Do install the proper chimney cap or chimney housing on the chimney to prevent rain and debris from entering the chimney.
12. Do keep all flammable liquids, gases and pressurized containers away from the fireplace.
13. Do check the fireplace for proper adjustment and operation before leaving it unattended for long periods of time.
14. Do inspect and clean the fireplace chimney regularly.
15. Do keep the firescreens closed when the fireplace is left unattended to minimize the danger of sparks popping out of the fireplace.
16. Do use the grate furnished with and for this fireplace.
17. Do start a fire only with paper, kindling or solid composition fire starters specifically designed for starting a fire. The use of liquid fire starters can cause an explosion within the fireplace.
18. Do place all ashes in a metal container with a tight fitting lid and place them on a noncombustible surface well away from other combustible materials until they have completely cooled.
19. Do store your fuel supply at a distance equal to or greater than the spacing recommended for combustible materials from the fireplace.
20. Do build fires of moderate intensity in the fireplace for the first three fires to allow the materials to adjust and cure before being subjected to the intense heat of a large fire.

DON'TS

1. Don't allow other installations or operation considerations to take priority over safety considerations.
2. Don't attempt to use the fireplace until the installation is complete.
3. Don't use unlisted parts and accessories with the fireplace except for special flashings that may be fabricated locally.
4. Don't use damaged parts or accessories with this fireplace.
5. Don't install the fireplace in an exposed or uninsulated area.
6. Don't install fireplace over carpeting.
7. Don't install the fireplace on a poorly constructed base or fail to fasten down or attach the fireplace to prevent it from shifting out of position.
8. Don't create or allow a crack to develop between the metal face of the fireplace and noncombustible trim.
9. Don't use power blowers or air circulation systems with this fireplace that are not specifically recommended by Martin Industries.
10. Don't connect accessory air circulation blowers to improperly fused or ungrounded electrical circuits.
11. Don't install the fireplace where flammable or explosive liquids or vapors are likely to be present.
12. Don't neglect all the considerations mentioned in this manual concerning clearances to combustibles, spacing from obstructions and proper chimney height when selecting the location and installing the chimney.
13. Don't allow insulating materials to contact the chimney.
14. Don't neglect to install the chimney thimble as required.
15. Don't neglect to apply caulking or mastic to the required joints of the flashing and between the flashing and roof.
16. Don't dry clothing or other articles near the fireplace.
17. Don't store or place flammable liquids, gases or pressurized containers near the fireplace.
18. Don't neglect to instruct all responsible persons in the proper and safe operation of the fireplace.
19. Don't fail to instruct all persons, especially children and elderly persons, concerning the hazards of improper operation and unauthorized tampering with the fireplace.
20. Don't use this fireplace to burn paper, cardboard, or other debris.
21. Don't neglect to inspect and clean the chimney regularly.
22. Don't operate the fireplace with the glass firescreen doors partially open. The doors should always be fully open or fully closed.

23. Don't use gasoline, kerosene, engine oil, charcoal lighter, or other flammable liquids to start or intensify a fire. Using these and similar materials can cause an explosion within the fireplace.
24. Don't store your fuel supply closer to the fireplace than the minimum spacing required for combustible materials.
25. Don't subject the fireplace to the intense heat of a large fire the first three times the fireplace is used, but build moderate fires to allow the materials to cure and adjust.
26. Don't clean the chimney with metallic devices or chemical cleaners.
27. Don't use the fireplace or chimney for venting wood or coal burning heaters or inserts.
28. Don't put combustibles within 24 inches of the fireplace opening, if doors are not installed. If doors are installed clearances to combustible perpendicular sidewall may be reduced to 12 inches minimum.

LIMITED WARRANTY

FACTORY-BUILT FIREPLACE AND COMPONENTS (except blowers)

Manufactured by: Martin Industries, Post Office Box 128, Florence, Alabama 35631

WHAT IS COVERED AND FOR HOW LONG

FIVE-YEAR COVERAGE:

For five years from the date this fireplace and components are first purchased for use, Martin Industries, Inc. will, at its option, repair or replace any defective part of this fireplace or components, or refund to you a sum not to exceed the factory published retail price in effect at the time of purchase.

TEN-YEAR COVERAGE:

From the sixth through the tenth year following the date this fireplace or accessory is first purchased for use, Martin Industries, Inc. will make available to you, at our factory, a free replacement for any defective part in this fireplace or accessory.

TWENTY-FIVE-YEAR AVAILABILITY OF REPLACEMENT PARTS:

From the eleventh through the twenty-fifth year following the date this fireplace or accessory is first purchased for use, Martin Industries, Inc. will make available at our factory replacement parts for this fireplace or accessory, which you may purchase for the list price current at the time your purchase order is received.

WHAT IS NOT COVERED

This limited warranty does not cover:

- Transportation or shipping cost
- The cost of a service call to diagnose trouble.
- Painted surfaces.
- Damage or defect caused by improper installation, accident, misuse, abuse, or alteration.
- Poor ventilation of smoke or gases caused by air-conditioning and heating systems, exhaust fans, or pressure differentials produced by wind.
- Broken glass components.
- Cracks in ceramic and castable parts that do not affect safe operation.
- We do not warrant this fireplace to be in compliance with your local building code. Building codes vary greatly throughout the country, and you should determine whether your local building code contains restriction on the use of this fireplace before you purchase it.
- Blowers or fans, which are warranted separately.
- Heat loss due to the passage of heat or air through or around the fireplace.

Also, under our five year coverage, we do not pay the cost of removal and replacement of any portion of the structure in which the fireplace is situated, made necessary by the repair, removal or re-installation of the fireplace.

And under our twenty-five-year warranty of availability of replacement parts, we only promise to maintain a supply of replacement parts at our factory for you to purchase.

LIMITATIONS AND EXCLUSIONS

1. No one has authority to add to or vary this limited warranty, or to create for Martin Industries, Inc. any other obligation or liability in connection with this fireplace and accessory.
2. MARTIN INDUSTRIES, INC. SHALL NOT BE LIABLE FOR INCIDENTAL, CONSEQUENTIAL, SPECIAL, OR CONTINGENT DAMAGES YOU MIGHT SUFFER AS A RESULT OF ITS BREACH OF THIS WRITTEN WARRANTY OR ANY IMPLIED WARRANTY. Some states do not allow the exclusion or limitation of incidental or consequential damages, so the above limitation or exclusion may not apply to you.
3. This warranty applies only to the original purchaser of the fireplace or to the original owner of the dwelling when the fireplace is installed in a new dwelling and may not be transferred.
4. This warranty applies only to a fireplace sold and used in the United States.

YOUR DUTIES

- This fireplace must be installed by a qualified installer according to your local building codes and installation instructions and operated according to the owner's instructions.
- You should keep a cancelled check or payment record to verify the purchase date.

IF YOU HAVE A PROBLEM WITH YOUR FIREPLACE OR COMPONENT

1. Contact the nearest Martin Industries, Inc. dealer. If you cannot locate your Martin Industries, Inc. dealer, call or write Martin Industries, Inc., Customer Service Department, as indicated below.
2. If you do not receive satisfactory service from the dealer within a reasonable time, write Martin Industries, Inc., Customer Service Department and include the date you purchased your fireplace or component, its serial number, and details of the problem you are having.

Customer Service Department, Martin Industries, Inc., Post Office Box 128, Florence, Alabama 35631, Telephone: 205-767-0330.

This warranty gives you specific legal rights, and you may also have other rights which vary from state to state.

